

MOUNTING HOLE DETAILS

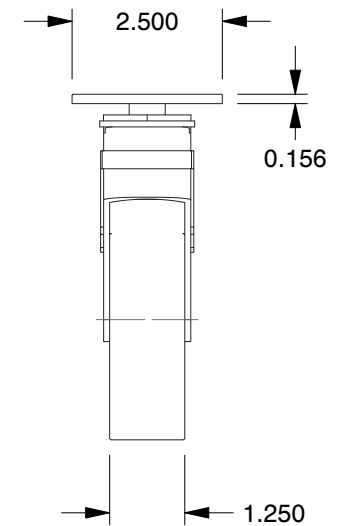
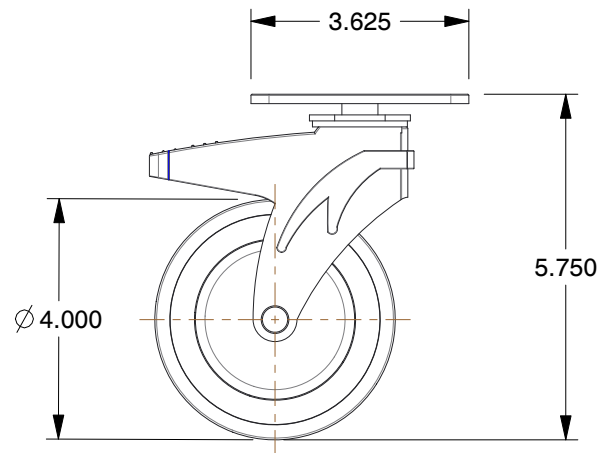
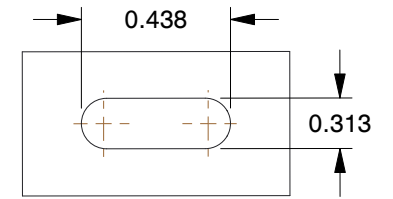

NOTES:

1. LOAD RATING : 275 lb.
2. WHEEL COLOR : Gray
3. CASTER WHEEL BEARINGS : Ball
4. CASTER FRAME MATERIAL : Nylon
5. CASTER WHEEL SHAPE : Standard
6. CASTER CORE MATERIAL : Polypropylene
7. CASTER WHEEL/TREAD MATERIAL : Thermoplastic Rubber
8. CASTER LOAD RATING RANGE : Light-Duty
9. CASTER PRODUCT GROUP : Swivel Caster with Total Lock

COMPONENT	Plate Caster
1MML4	UNIT
Swl Plt Cstr w/Total-Lock, 4" dia, 275 lb.	INCH
	SHEET
	1 of 1



100 Grainger Parkway, Lake Forest, Illinois 60045-5201
 1-(800) GRAINGER, 1-(800) 472-4643, (847) 535-1000
 www.grainger.com

This file and any associated information and specifications are provided for reference and evaluation purposes only, and is subject to change without notice. Grainger makes no representations, warranties or guarantees as to the appropriateness, accuracy, completeness, or suitability for any purpose, of the file, information or specifications. You are solely responsible for the use of the file, information or specifications.

This drawing is the property of GRAINGER. It contains confidential, proprietary information that is GRAINGER property. Do not disclose to or duplicate for others except as authorized by GRAINGER.

SCALE 0.31