

<sup>®</sup>  
**Dayton**



## **Wall-Mount Cabinet Exhaust and Supply Fans**

**Models 1AHB6 thru 1AHB9, 1AHD1 thru  
1AHD7, 1AJA7 thru 1AJA9, 1AJB1, 1RBD8,  
6LFC2A thru 6LFC5A**

®  
**Dayton**

**PLEASE READ AND SAVE  
THESE INSTRUCTIONS.**

**READ CAREFULLY  
BEFORE ATTEMPTING  
TO ASSEMBLE, INSTALL,  
OPERATE OR MAINTAIN THE  
PRODUCT DESCRIBED.**

**PROTECT YOURSELF AND  
OTHERS BY OBSERVING ALL  
SAFETY INFORMATION. FAILURE  
TO COMPLY WITH INSTRUCTIONS  
COULD RESULT IN PERSONAL  
INJURY AND/OR PROPERTY  
DAMAGE! RETAIN INSTRUCTIONS  
FOR FUTURE REFERENCE.**

**PLEASE REFER TO BACK COVER  
FOR INFORMATION REGARDING  
DAYTON'S WARRANTY AND OTHER  
IMPORTANT INFORMATION.**

**Model #:** \_\_\_\_\_

**Serial #:** \_\_\_\_\_

**Purch. Date:** \_\_\_\_\_

*Form 5S6827 / Printed in USA  
04632 Version 1 11/2014*

**© 2006 - 2014 Dayton Electric Manufacturing Co.  
All Rights Reserved**

## BEFORE YOU BEGIN

### **⚠ WARNING**

*Installation, troubleshooting and parts replacement are to be performed only by qualified personnel.*



#### **Electrical Requirements:**

- The motor amperage and voltage ratings must be checked for compatibility to supply voltage prior to final electrical connection. Wiring must conform to local and national codes.



#### **Tools Needed:**

- Mounting Fasteners (8)
- Sealant or Caulk
- Tachometer

#### **Recommended Accessories:**

- NEMA 1 (1H400, 1H401) / NEMA 4 (1H408, 1H409) Disconnect Switch
- Weatherhood (1WBV9, 1WBW1 - 1WBW5)

## UNPACKING



#### **Contents:**

- Hardware Kit (1)
- Mounting Angle (4)
- Dayton® Wall-Mount Cabinet Fan (1)
- Operating Instructions and Parts Manual (1)



#### **Inspect:**

- After unpacking unit, inspect carefully for any damage that may have occurred during transit. Check for loose, missing, or damaged parts. Shipping damage claim must be filed with carrier.
- Look for hardware kit and mounting angles attached to drive frame channel of fan. Access by removing the intake guard.
- Check all bolts, screws, set-screws, etc. for looseness that may have occurred during transit. Retighten as required. Rotate propeller by hand to be sure it turns freely.



- See **General Safety Instructions** on page 2, and **Cautions and Warnings** as shown.

## GENERAL SAFETY INSTRUCTIONS

Fans are UL/cUL Listed Subject 705.

**NOTE:** Fan drives feature a variable pitch motor pulley to reduce fan speed a maximum of 25% to provide proper air volume for specific applications.

**⚠ DANGER** *Do not depend on any switch as the sole means of disconnecting power when installing or servicing the fan. Always disconnect, lock and tag power source before installing or servicing. Failure to disconnect power source can result in fire, shock or serious injury. Motor will restart without warning after thermal protector trips. Do not touch operating motor, it may be hot enough to cause injury.*

**⚠ DANGER** *Do not place any body parts or objects in fan, motor openings or drives while motor is connected to power source.*

**⚠ WARNING** *Do not use this equipment in explosive atmospheres.*

1. Read and follow all instructions and cautionary markings. Make sure electrical power source conforms to requirements of equipment and local codes.
2. Fans should be assembled, installed and serviced by a qualified technician. Have all electrical work performed by a qualified electrician.
3. Follow all local electrical and safety codes in the United States and Canada, as well as the National Electrical Code (NEC), and the Occupational Safety and Health Act (OSHA) in the United States. Ground motor in accordance with NEC Article 250 (grounding). Follow the Canadian Electric Code (CEC) in Canada.
4. The rotation of the propeller is critical. It must be free to rotate without striking or rubbing the venturi.
5. Unit must be securely and adequately grounded.
6. Do not spin fan propeller faster than max cataloged fan RPM. Adjustments to fan speed significantly affects motor load. If the fan RPM is changed, the motor current should be checked to make sure it is not exceeding the motor nameplate amps.
7. Do not kink power cable or allow it to come in contact with sharp objects, oil, grease, hot surfaces or chemicals. Replace damaged cords immediately.

**⚠ CAUTION** *To reduce the risk of injury to persons, observe the following:*

**OSHA requires OSHA complying guards when fan is installed within 7 feet of floor or working level.**

**UL/cUL Standards require OSHA complying guards when fan is installed within 8 feet of floor or working level.**

## SPECIFICATIONS

Max. Ambient Temp.	104°F
Mounting Position	Vertical
Housing Material	Galvanized Steel
Wheel Type	Aluminum, Backward Inclined Centrifugal
Includes	Wall-Mounting Angles
Agency Compliance	UL/cUL 705, AMCA Sound and Air



### Dimensions (inches)

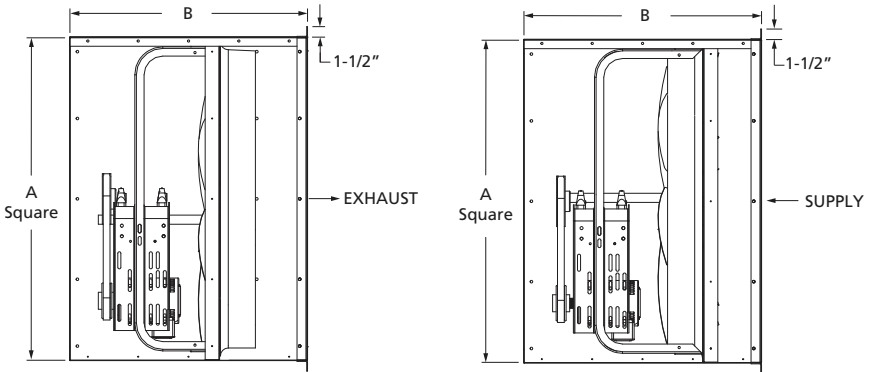

Figure 1

	1AHB6 1AHB7 1AJA7	1AHB8 1AHB9 1AJA8	1AHD1 1AHD2 1AJA9	1AHD3 1AHD4 6LFC2A 6LFC3A	1AHD5 1AHD6 6LFC4A 6LFC5A 1AJB1	1AHD7 1RBD8
A	28-1/4	34-1/4	40-1/4	46-1/4	54-1/4	60-1/4
B	34-1/8	34-1/8	34-5/8	34-5/8	36-5/8	39-5/8
Number of Blades	5	5	5	5	5	5
Propeller Dia.	24	30	36	42	48	54
Shaft Dia.	3/4	1	1	1-1/4	1-1/4	1-1/4
Recommended Wall Opening (Sq.)	29-1/4	35-1/4	41-1/4	47-1/4	55-1/4	61-1/4
Recommended Weather Hood	1WBV9	1WBW1	1WBW2	1WBW3	1WBW4	1WBW5



## PERFORMANCE

Model, Assembled	115/208-230	HP	RPM	Max BHP	Sones @ .25" SP @ 5 Ft.	CFM Air Delivery @ Static Pressure Shown				
						0.00"	0.125"	0.25"	0.375"	0.50"

### Exhaust Fans

1AHB6	1/2	765	0.06	8.3	833	754	665	565	408
1AHB8	3/4	651	0.26	12.0	1413	1365	1313	1251	1189
1AHD1	1	534	0.26	12.2	1665	1595	1528	1463	1398
1AHD3	1	422	0.34	14.0	1824	1760	1699	1639	1580
1AHD5	1	354	0.48	16.7	2037	1979	1923	1869	1816

### Supply Fans

1AJA7	1/2	778	0.20	13.0	1260	1209	1156	1100	1041
1AJA8	1	720	0.35	13.4	1549	1505	1459	1406	1350

Model, Assembled	208-230/460	HP	RPM	Max BHP	Sones @ .25" SP @ 5 Ft.	CFM Air Delivery @ Static Pressure Shown				
						0.00"	0.125"	0.25"	0.375"	0.50"

### Exhaust Fans

1AHB7	3/4	877	0.86	21	5796	4950	4165	3020	—
1AHB9	1	717	1.18	24	9408	8131	6633	4431	2070
1AHD2	1-1/2	611	1.73	22	14,148	12,611	10,527	7608	4298
1AHD4	1-1/2	482	1.73	23	16,386	14,520	11,551	7342	4061
6LFC2A	3	608	3.45	24	20,669	19,312	17,640	14,939	11,769
6LFC3A	5	720	5.75	46	24,477	23,361	22,019	20,618	18,044
1AHD6	2	445	2.31	20	23,174	19,870	15,154	11,025	7140
6LFC4A	3	511	3.45	36	26,611	23,913	19,100	15,982	12,511
6LFC5A	5	605	5.75	53	31,506	29,520	26,636	22,194	19,601
1AHD7	5	518	5.53	34	35,881	34,002	31,574	26,743	22,462

### Supply Fans

1AJA9	1-1/2	619	1.73	23	13,913	12,435	10,110	6637	—
1AJB1	2	440	2.31	19.5	23,177	19,858	15,591	9701	—
1RBD8	5	520	5.65	31	36,830	34,067	31,251	27,751	23,719

Performance certified is for installation type A: Free inlet, Free outlet. Power rating (BHP) does not include transmission losses. Performance ratings include the effects of a birdscreen and damper in the airstream. The sound ratings shown are loudness values in fan sones at 5 ft. (1.5 m) in a hemispherical free field calculated per AMCA Standard 301. Values shown are for installation type A: Free inlet hemispherical sone levels.



Dayton Electric Mfg. Co. certifies that the ventilators shown herein are licensed to bear the AMCA seal. The ratings shown are based on tests and procedures performed in accordance with AMCA Publication 211 and AMCA Publication 311 and comply with the requirements of the AMCA Certified Ratings Program.

## INSTALLATION INSTRUCTIONS

**⚠ WARNING** *Installation, troubleshooting and parts replacement are to be performed only by qualified personnel.*

**⚠ CAUTION** *Not recommended for portable or mobile installations or suspension mounting with wire or chain.*

**NOTE:** Refer to motor nameplate for wiring procedures. Refer to switch manufacturer for installation and wiring procedures.

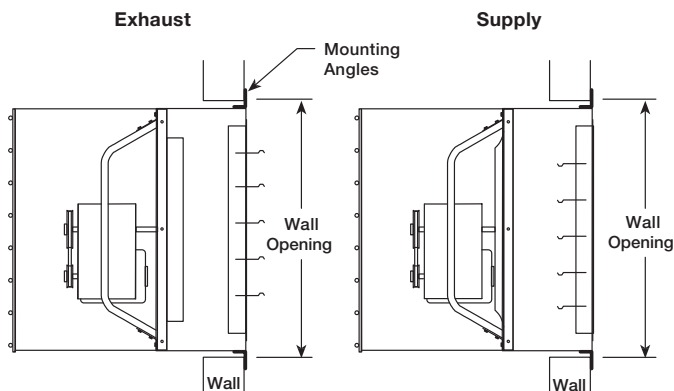

**Figure 2**

1. Fans should be installed in a framed rigid wall opening located where there will be no obstruction to the flow of air into or out of the fan.
2. Once a location has been determined; an opening should be made in the wall and framed to provide 1/4 to 1/2 inch total clearance around the fan housing. Refer to Dimension table for recommended wall opening size.
3. Framing must be able to support the weight of fan assembly. Reinforce wall, depending on the construction of the wall.
4. Hardware kit and mounting angles are attached to drive frame channel of fan. Access by removing the intake guard.

**NOTE:** The guard may be pivoted up, or down, by removing all but the (2) top, or bottom, corner fasteners. Corner fasteners can act as hinges to pivot guard and secure it out of the way.

5. Position fan assembly in the framed opening. For maximum weather protection, it is recommended that the fan housing extend beyond the exterior of the building as little as possible. Supply fans require a weatherhood to reduce the risk of moisture entering the building.
6. Attach (4) mounting angles to the fan housing and wall framing. Refer back to Figure 2.
  - a. Use pre-punched holes in mounting angle as a template for drilling holes in fan housing.

- b. Bolt angles to housing using 5/16-18 inch bolts and 5/16 inch nuts, every hole must be used. Do not skip holes.
- c. Mounting angles must be securely fastened to wall framing using hardware (by others) appropriate for the wall construction.

**NOTE:** Fan housing must be square in the wall opening. The housing should be level or tilted a maximum of 5° down to the exhaust side.

7. Any gap between the fan housing and the wall opening should be sealed from the outside of the building.

### Electrical Connection



**CAUTION** All electrical connections should be performed by a qualified electrician.



**WARNING** To reduce the risk of electrical shock - do not connect to a circuit operating at more than 150V to ground.

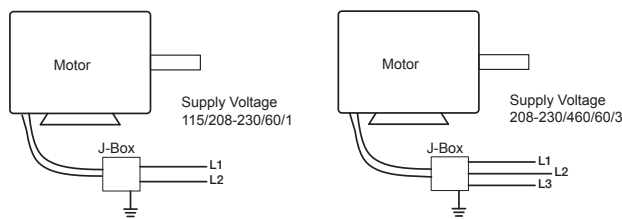

**Figure 3**

**NOTE:** Refer to motor nameplate for wiring procedures.

1. Motor and fan must be securely grounded (bare metal) to a suitable electric ground, such as a grounded water pipe or ground wire system.
2. Connect power to motor using an approved wiring method. Motor terminal connection data is provided on the motor nameplate and on the motor terminal box cover plate. Use adequate size wire for all branch and feeder runs.

**NOTE:** Motor cable should be routed through fan housing using any one of the knock-out positions provided. Use grommet provided to protect the motor cable from knock-out hole edges.

3. Before activating fan, inspect to be sure that there are no obstructions or debris that would interfere with propeller or shutter.
4. Reposition intake guard and reinstall all fasteners. To avoid stripping the threads, do not overtighten fasteners.
5. Unit is ready for operation.



## OPERATION

1. Before starting up or operating your new Dayton® fan, check all fasteners for tightness. In particular, check bearing set screws in propeller hub (and sheaves, if applicable). While in the OFF position, or before connecting the fan to power, turn the fan propeller by hand to be sure it is not striking the orifice or any obstacle.
2. Check wheel rotation by momentarily energizing the unit. Rotation should be in the same direction as the rotation decal affixed to the unit or as shown in Figure 4.

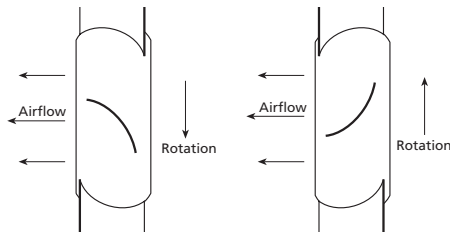
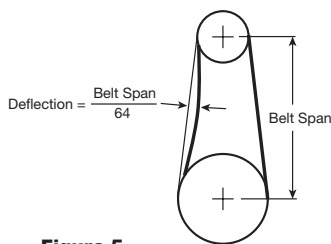

**Figure 4**

**NOTE:** For 3-phase installations, fan rotation can be reversed by interchanging any two of the three electrical leads. For single phase installations, follow the wiring diagram located on the motor.

**IMPORTANT:** Rotation of the wheel is critical and incorrect rotation will result in reduced air performance, increased motor loading and possible motor burnout.

3. When the fan is started, observe the operation and check for any unusual noises.
4. With the system in full operation, measure current (amps) input to the motor and compare with the nameplate rating (full-load amps) to determine if the motor is operating under safe load conditions.
5. Adjust RPM to desired level using a variable pitch sheave. After adjustment, motor amperage should be checked to avoid overloading of the motor.
6. Check belt tension two times during the first 24 hours of operation and periodically thereafter. To adjust belt tension, simply loosen four fasteners (two on each side of the motor plate) and slide the motor plate away from the fan shaft until proper belt tension is attained. On some fans, fasteners attaching the motor to the motor plate must be loosened in order to adjust the belt.



**Figure 5**

On some fans, fasteners attaching the motor to the motor plate must be loosened in order to adjust the belt.

It is very important that the drive pulleys remain in proper alignment after adjustments are made. Misalignment of pulleys will result in premature belt wear noise, vibration and power loss.

**IMPORTANT:** Adjust (tighten) belt tension after the first 24-48 hours of operation.

7. Keep inlets and approaches to fan clean and free from obstruction.

## TROUBLESHOOTING GUIDE

Symptom	Possible Cause(s)	Corrective Action
Fan inoperative	1. Blown fuse or breaker	1. Replace or repair
	2. Defective motor	2. Replace or repair
	3. Incorrectly wired	3. Shut power OFF and check wiring for proper connections
	4. Broken belts	4. Replace
	5. Loose pulley(s)	5. Check alignment and tighten
	6. Electricity turned off	6. Contact local power company
Excessive noise or vibration	1. Belt(s) too loose/tight	1. Adjust tension
	2. Belt(s) worn, oily or dirty	2. Clean or replace
	3. Loose or defective bearings	3. Tighten or replace
	4. Foreign material inside bearing	4. Replace bearing
	5. Pulley not tightened on shaft	5. Check alignment and tighten set screws and/or bushing screws
	6. Loose propeller	6. Tighten set screws or taper bushing screws
	7. Crooked or damaged propeller	7. Replace
	8. Bent fan shaft	8. Replace
	9. Mis-aligned sheaves	9. Re-align
	10. Fan not securely anchored	10. Secure properly
	11. Fan propeller out of balance	11. Replace
Insufficient airflow	1. Damper closed	1. Inspect/repair
	2. Speed too slow	2. Check for correct drives
	3. Belt slippage	3. Replace/adjust tension
	4. Incorrect propeller rotation	4. Check motor wiring
	5. Insufficient static pressure	5. Check static pressure calculation, increase turns open on VP pulley
Motor overloads or overheats	1. Propeller RPM too high	1. Check drives, increase turns open on VP pulley
	2. Shorted motor winding	2. Replace motor
	3. Incorrect propeller rotation	3. Check motor wiring
	4. Over/Under line voltage	4. Contact local power company
	5. Belt slippage	5. Tighten belt

## MAINTENANCE

### **⚠ WARNING**

**Disconnect and lockout power source before servicing.**

### **⚠ CAUTION**

**Uneven cleaning of the propeller will produce an out of balance condition that will cause vibration in the fan.**

1. Once the fan has been put into operation, a periodic maintenance program should be set up to preserve the reliability and performance of the fan. Items to be included in this program are belts, bearings, fasteners and set screws, lubrication, and removal of dust and dirt.
2. Check for unusual noises when ventilator is running.
3. Periodically inspect and tighten set screws.
4. Periodically check belts for wear and tightness.

**NOTE:** When replacing belts use the same type as supplied with the unit.

**NOTE:** For belt replacement, loosen the motor mounting hardware to allow removal of the belt by hand.

### **⚠ CAUTION**

**Do not force belts on or off. This may cause cords to break, leading to premature belt failure.**

5. Follow motor manufacturer's instructions for motor lubrication.
6. Keep bearings clean and well lubricated (where applicable). Bearings are the most critical moving part of the fan and should be inspected at periodic intervals. Locking collars and set screws, in addition to fasteners attaching the bearings to the bearing plate, must be checked for tightness.
  - a. In a clean environment and temperatures above 32°F (0°C) and below 200°F (93°C), fan shaft bearings with grease fittings should be lubricated semi-annually using a high-quality lithium based grease.
  - b. If unusual environmental conditions exist, temperatures below 32°F (0°C) and above 200°F (93°C), moisture or contaminants, more frequent lubrication is required.
  - c. With the unit running, add grease very slowly with a manual grease gun until a slight bead of grease forms at the seal. Be careful not to unseat the seal by over lubricating or using excessive pressure.

**NOTE:** Sealed pillow block bearings require no further lubrication.

7. For critical applications, a spare motor and belts should be available.

**REPAIR PARTS ILLUSTRATION FOR WALL-MOUNT CABINET EXHAUST FANS**

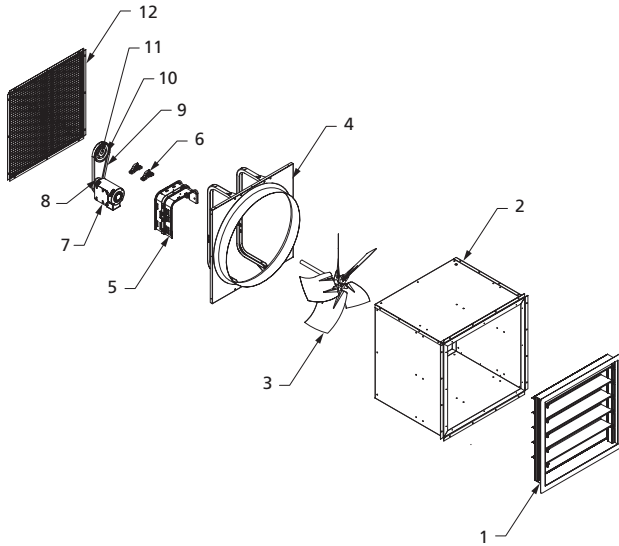

**REPAIR PARTS LIST FOR WALL-MOUNT CABINET EXHAUST FANS**

Ref. No.	Description	Part Number for Models:					Qty.
		1AHB6	1AHB7	1AHB8	1AHB9	1AHD1	
1	Backdraft Damper	21DR34	21DR34	21DR35	21DR35	21DR36	1
2	Housing	21DR71	21DR71	21DR72	21DR72	21DR73	1
3	Propeller and Shaft	21DR95	21DR95	21DR97	21DR97	21DR99	1
4	Fan Panel and Drive Frame Assembly	21DR50	21DR50	21DR53	21DR53	21DR56	1
5	Motor Bearing Plate	21DR77	21DR77	21DR77	21DR78	21DR79	1
6	Bearing	21DW60	21DW60	21DT70	21DT70	21DT70	2
7	Motor	21DT30	21DT31	21DT32	21DT33	21DT34	1
8	Driver Sheave	3X264	3X264	3X264	3X264	3X276	1
9	Belt	4L340	4L320	1A100	6A146	3X472	1
10	Driven Sheave	3X599	3X597	3X602	3X600	3X607	1
11	Driven Bushing	3X573	3X573	3X576	3X576	3X576	1
12	Birdscreen†	21DR44	21DR44	21DR45	21DR45	21DR46	1 / 2
*	Hardware Kit‡	21DR69	21DR69	21DR69	21DR69	21DR69	1

**For Repair Parts, call 1-800-Grainger  
24 hours a day – 365 days a year**

*Please provide following information:*

- Model number
- Serial number (if any)
- Part description and number as shown in parts list

Ref. No.	Description	Part Number for Models:					Qty.
		1AHD2	1AHD3	1AHD4	1AHD5	1AHD6	
1	Backdraft Damper	21DR36	21DR37	21DR37	21DR38	21DR38	1
2	Housing	21DR73	21DR74	21DR74	21DR75	21DR75	1
3	Propeller and Shaft	21DR99	21DT02	21DT02	21DT03	21DT03	1
4	Fan Panel and Drive Frame Assembly	21DR56	21DR59	21DR59	21DR61	21DR61	1
5	Motor Bearing Plate	21DR79	21DR81	21DR81	21DR81	21DR81	1
6	Bearing	21DT70	21DW58	21DW58	21DW58	21DW58	2
7	Motor	21DX32	21DT34	21DX32	21DT34	21DX33	1
8	Driver Sheave	3X500	3X264	3X500	3X264	3X503	1
9	Belt	3X621	3X623	3X704	6X569	6L182	1
10	Driven Sheave	3X603	3X609	3X607	3X610	3X610	1
11	Driven Bushing	3X576	3X579	3X579	3X579	3X579	1
12	Birdscreen†	21DR46	21DR47	21DR47	21DR48	21DR48	1 / 2
*	Hardware Kit‡	21DR69	21DR70	21DR70	21DR70	21DR70	1

Ref. No.	Description	Part Number for Models:					Qty.
		1AHD7	6LFC2A	6LFC3A	6LFC4A	6LFC5A	
1	Backdraft Damper	21DR39	21DR37	21DR37	21DR38	21DR38	1
2	Housing	21DR76	21DR74	21DR74	21DR75	21DR75	1
3	Propeller and Shaft	21DT05	36FL74	36FL74	21EA10	21EA10	1
4	Fan Panel and Drive Frame Assembly	21DR64	21DR59	21DR59	21DR61	21DR61	1
5	Motor Bearing Plate	21DR84	21DR81	21DR81	21DR81	21DR81	1
6	Bearing	21DW58	21DW58	21DW58	21DW58	21DW58	2
7	Motor	21DW51	6XWJ0	21DW51	6XWJ0	21DW51	1
8	Driver Sheave	3X401	5UHU0	5UHV3	5UHU0	5UHV3	1
9	Belt	6L182	3X547	1A108	3X625	6A157	1
10	Driven Sheave	1W963	5RJG8	5RJG8	5RJG9	5RJG9	1
11	Driven Bushing	3X579	5UHZ4	5UHZ4	5UHZ4	5UHZ4	1
12	Birdscreen†	21DR49	21DR47	21DR47	21DR48	21DR48	1 / 2
*	Hardware Kit‡	21DR70	21DR70	21DR70	21DR70	21DR70	1

\* Not Shown.

† One Birdscreen is required for models 1AHD6 thru 1AHD9, 1AHD1 thru 1AHD4. Two Birdscreens are required for models 1AHD5 thru 1AHD7, 6LFC4 and 6LFC5.

‡ Hardware Kit 21DR69 includes (12) 5/16-18 Spin-lock Nuts and (12) 5/16-18 x 3/4 Spin-lock Bolts. Hardware Kit 21DR70 includes (20) 5/16-18 Spin-lock Nuts and (20) 5/16-18 x 3/4 Spin-lock Bolts.

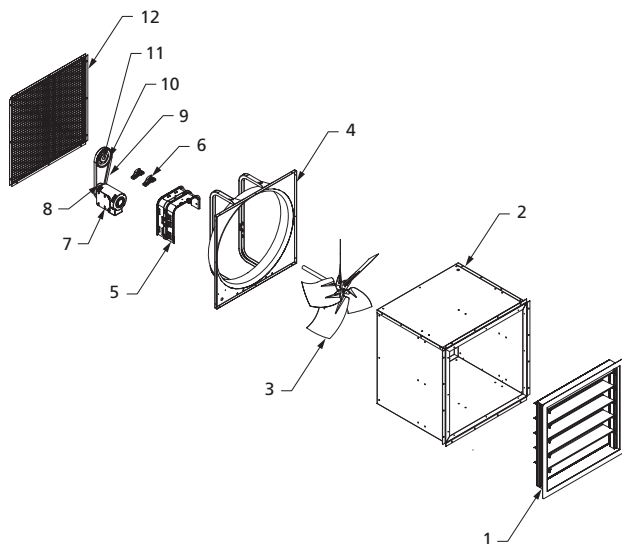
**REPAIR PARTS ILLUSTRATION FOR WALL-MOUNT CABINET  
SUPPLY FANS**

**For Repair Parts, call 1-800-Grainger  
24 hours a day – 365 days a year**

*Please provide following information:*

- Model number
- Serial number (if any)
- Part description and number as shown in parts list

## REPAIR PARTS LIST FOR WALL-MOUNT CABINET SUPPLY FANS

Ref. No.	Description	Part Number for Models:					Qty.
		1AJA7	1AJA8	1AJA9	1AJB1	1RBD8	
1	Backdraft Damper	21DR40	21DR41	21DR42	21DR43	21DY34	1
2	Housing	21DR71	21DR72	21DR73	21DR75	21DR76	1
3	Propeller and Shaft	21DR96	21DR98	21DT01	21DT04	21DY33	2
4	Fan Panel and Drive Frame Assembly	21DR51	21DR54	21DR57	21DR62	21DY35	1
5	Motor Bearing Plate	21DR77	21DR78	21DR79	21DR81	21DR84	1
6	Bearing	21DW60	21DT70	21DT70	21DW58	21DW58	1
7	Motor	21DT30	21DT34	21DX32	21DX33	21DW51	1
8	Driver Sheave	3X276	3X276	3X500	3X500	3X400	1
9	Belt	6A143	6A146	1A109	3X704	6L182	1
10	Driven Sheave	3X600	3X602	3X603	3X608	1W963	1
11	Driven Bushing	3X573	3X576	3X576	3X579	3X579	1
12	Birdscreen†	21DR44	21DR45	21DR46	21DR48	21DR49	1 / 2
*	Hardware Kit‡	21DR69	21DR69	21DR69	21DR70	21DR70	1

\* Not Shown.

† One Birdscreen is required for models 1AJA7 thru 1AJA9. Two Birdscreens are required for models 1AJB1 and 1RBD8.

‡ Hardware Kit 21DR69 includes (12) 5/16-18 Spin-lock Nuts and (12) 5/16-18 x 3/4 Spin-lock Bolts. Hardware Kit 21DR70 includes (20) 5/16-18 Spin-lock Nuts and (20) 5/16-18 x 3/4 Spin-lock Bolts.

## **DAYTON ONE-YEAR LIMITED WARRANTY**

**DAYTON ONE-YEAR LIMITED WARRANTY.** All Dayton® product models covered in this manual are warranted by Dayton Electric Mfg. Co. ("Dayton") to the original user against defects in workmanship or materials under normal use for one year after date of purchase. If the Dayton product is part of a set, only the portion that is defective is subject to this warranty. Any product or part which is determined to be defective in material or workmanship and returned to an authorized service location, as Dayton or Dayton's designee designates, shipping costs prepaid, will be, as the exclusive remedy, repaired or replaced with a new or reconditioned product or part of equal utility or a full refund given, at Dayton's or Dayton's designee's option, at no charge. For limited warranty claim procedures, see "Warranty Service" below. This warranty is void if there is evidence of misuse, mis-repair, mis-installation, abuse or alteration. This warranty does not cover normal wear and tear of Dayton products or portions of them, or products or portions of them which are consumable in normal use. This limited warranty gives purchasers specific legal rights, and you may also have other rights which vary from jurisdiction to jurisdiction.

### **WARRANTY DISCLAIMERS AND LIMITATIONS OF LIABILITY RELATING TO ALL CUSTOMERS FOR ALL PRODUCTS**

**LIMITATION OF LIABILITY.** TO THE EXTENT ALLOWABLE UNDER APPLICABLE LAW, DAYTON'S LIABILITY FOR CONSEQUENTIAL AND INCIDENTAL DAMAGES IS EXPRESSLY DISCLAIMED. DAYTON'S LIABILITY IN ALL EVENTS IS LIMITED TO AND SHALL NOT EXCEED THE PURCHASE PRICE PAID.

**WARRANTY DISCLAIMER.** A DILIGENT EFFORT HAS BEEN MADE TO PROVIDE PRODUCT INFORMATION AND ILLUSTRATE THE PRODUCTS IN THIS LITERATURE ACCURATELY; HOWEVER, SUCH INFORMATION AND ILLUSTRATIONS ARE FOR THE SOLE PURPOSE OF IDENTIFICATION, AND DO NOT EXPRESS OR IMPLY A WARRANTY THAT THE PRODUCTS ARE MERCHANTABLE, OR FIT FOR A PARTICULAR PURPOSE, OR THAT THE PRODUCTS WILL NECESSARILY CONFORM TO THE ILLUSTRATIONS OR DESCRIPTIONS. EXCEPT AS PROVIDED BELOW, NO WARRANTY OR AFFIRMATION OF FACT, EXPRESSED OR IMPLIED, OTHER THAN AS STATED IN THE "LIMITED WARRANTY" ABOVE IS MADE OR AUTHORIZED BY DAYTON.

**PRODUCT SUITABILITY.** MANY JURISDICTIONS HAVE CODES AND REGULATIONS GOVERNING SALES, CONSTRUCTION, INSTALLATION, AND/OR USE OF PRODUCTS FOR CERTAIN PURPOSES, WHICH MAY VARY FROM THOSE IN NEIGHBORING AREAS. WHILE ATTEMPTS ARE MADE TO ASSURE THAT DAYTON PRODUCTS COMPLY WITH SUCH CODES, DAYTON CANNOT GUARANTEE COMPLIANCE, AND CANNOT BE RESPONSIBLE FOR HOW THE PRODUCT IS INSTALLED OR USED. BEFORE PURCHASE AND USE OF A PRODUCT, REVIEW THE SAFETY/SPECIFICATIONS, AND ALL APPLICABLE NATIONAL AND LOCAL CODES AND REGULATIONS, AND BE SURE THAT THE PRODUCT, INSTALLATION, AND USE WILL COMPLY WITH THEM.

**CONSUMERS ONLY.** CERTAIN ASPECTS OF DISCLAIMERS ARE NOT APPLICABLE TO CONSUMER PRODUCTS SOLD TO CONSUMERS; (A) SOME JURISDICTIONS DO NOT ALLOW THE EXCLUSION OR LIMITATION OF INCIDENTAL OR CONSEQUENTIAL DAMAGES, SO THE ABOVE LIMITATION OR EXCLUSION MAY NOT APPLY TO YOU; (B) ALSO, SOME JURISDICTIONS DO NOT ALLOW A LIMITATION ON HOW LONG AN IMPLIED WARRANTY LASTS, SO THE ABOVE LIMITATION MAY NOT APPLY TO YOU; AND (C) BY LAW, DURING THE PERIOD OF THIS LIMITED WARRANTY, ANY IMPLIED WARRANTIES OF MERCHANTABILITY OR FITNESS FOR A PARTICULAR PURPOSE APPLICABLE TO CONSUMER PRODUCTS PURCHASED BY CONSUMERS, MAY NOT BE EXCLUDED OR OTHERWISE DISCLAIMED.

THIS LIMITED WARRANTY ONLY APPLIES TO UNITED STATES PURCHASERS FOR DELIVERY IN THE UNITED STATES.

### **WARRANTY SERVICE**

To obtain warranty service if you purchased the covered product directly from W.W. Grainger, Inc. ("Grainger"), (i) write or call or visit the local Grainger branch from which the product was purchased or another Grainger branch near you (see [www.grainger.com](http://www.grainger.com) for a listing of Grainger branches); or (ii) contact Grainger by going to [www.grainger.com](http://www.grainger.com) and clicking on the "Contact Us" link at the top of the page, then clicking on the "Email us" link; or (iii) call Customer Care (toll free) at 1-888-361-8649. To obtain warranty service if you purchased the covered product from another distributor or retailer, (i) go to [www.grainger.com](http://www.grainger.com) for Warranty Service; (ii) write or call or visit a Grainger branch near you; or (iii) call Customer Care (toll free) at 1-888-361-8649. In any case, you will need to provide, to the extent available, the purchase date, the original invoice number, the stock number, a description of the defect, and anything else specified in this Dayton One-Year Limited Warranty. You may be required to send the product in for inspection at your cost. You can follow up on the progress of inspections and corrections in the same ways. Title and risk of loss pass to buyer on delivery to common carrier, so if product was damaged in transit to you, file claim with carrier, not retailer, Grainger or Dayton. For warranty information for purchasers and/or delivery outside the United States, please use the following applicable contact information:

**Dayton Electric Mfg. Co.,  
100 Grainger Parkway, Lake Forest, IL 60045 U.S.A.  
or call +1-888-361-8649**