

# Dayton Utility Pumps

## PUMPS technical data sheet



Submersible Utility / Dewatering pumps are designed for fluid transfer or dewatering applications. These pumps are typically used for temporary rain water removal and are designed to operate continuously. Utility pumps typically do not have automatic float switches, but do have broader head and flow ranges to accommodate higher performance requirements of dewatering applications.



### 4LA43 1¼ HP, Stainless Steel Submersible Dewatering Pump

<b>HP</b>	1-1/4
<b>Voltage</b>	120V
<b>Phase</b>	Single
<b>Frequency</b>	60 Hz
<b>Run Amps</b>	15A
<b>Start Amps</b>	32.5A
<b>RPM</b>	3450
<b>Motor Type</b>	Capacitor Start / Capacitor Run

<b>Overload Protection</b>	Internal Thermal Overload
<b>Motor Shaft Material</b>	420 Stainless Steel
<b>Motor Housing Material</b>	304 Stainless Steel and Composite
<b>Motor Duty</b>	Continuous
<b>Motor End Bearing</b>	Single Row Ball
<b>Pump End Bearing</b>	Single Row Ball
<b>Lubrication</b>	Oil Lubricated
<b>Discharge</b>	2 Inch MNPT Flanged
<b>Volute Material</b>	Polyurethane
<b>Base Material</b>	Rubberized Urethane
<b>Impeller Type</b>	Open Vortex
<b>Impeller Material</b>	Polyurethane
<b>Hardware Material</b>	300 Series Stainless Steel
<b>O-rings</b>	Buna-N
<b>Seal Type</b>	Dual Mechanical
<b>Seal Materials</b>	Silicon Carbide/Silicon Carbide/Buna-N
<b>Operation</b>	Manual Operation
<b>Power Cord</b>	14/3 SJTOW, 50' (15.2m), NEMA 5-15P 120V Plug
<b>Max. Solids Handling</b>	1/4" (6.4mm) spherical
<b>Max. Water Temperature</b>	104°F (40°C)
<b>Designed Fluid Environment</b>	Water / Wastewater

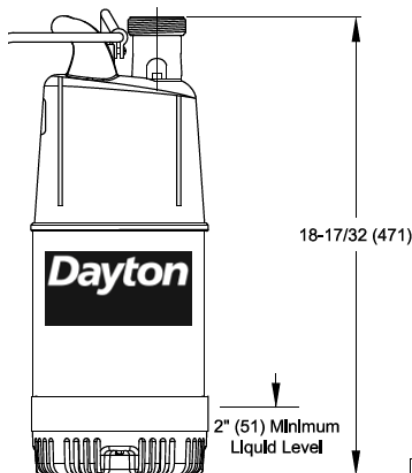

### Outline Dimensions

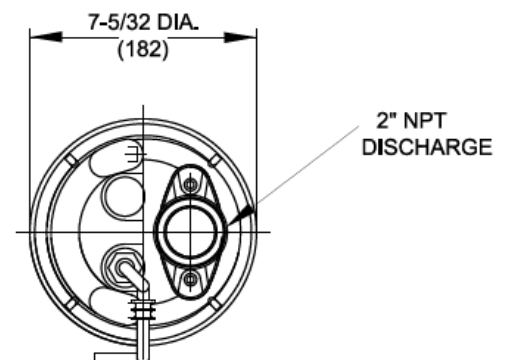

## Performance Data

Head	Feet	15	20	25	30	35	40	45	50
	Meters	4.6	6.1	7.6	9.1	10.7	12.2	13.7	15.2
Flow Rate	GPM	104	95	85	74	62	46	26	0
	LPM	394	360	322	280	235	174	98	0

## Performance Chart

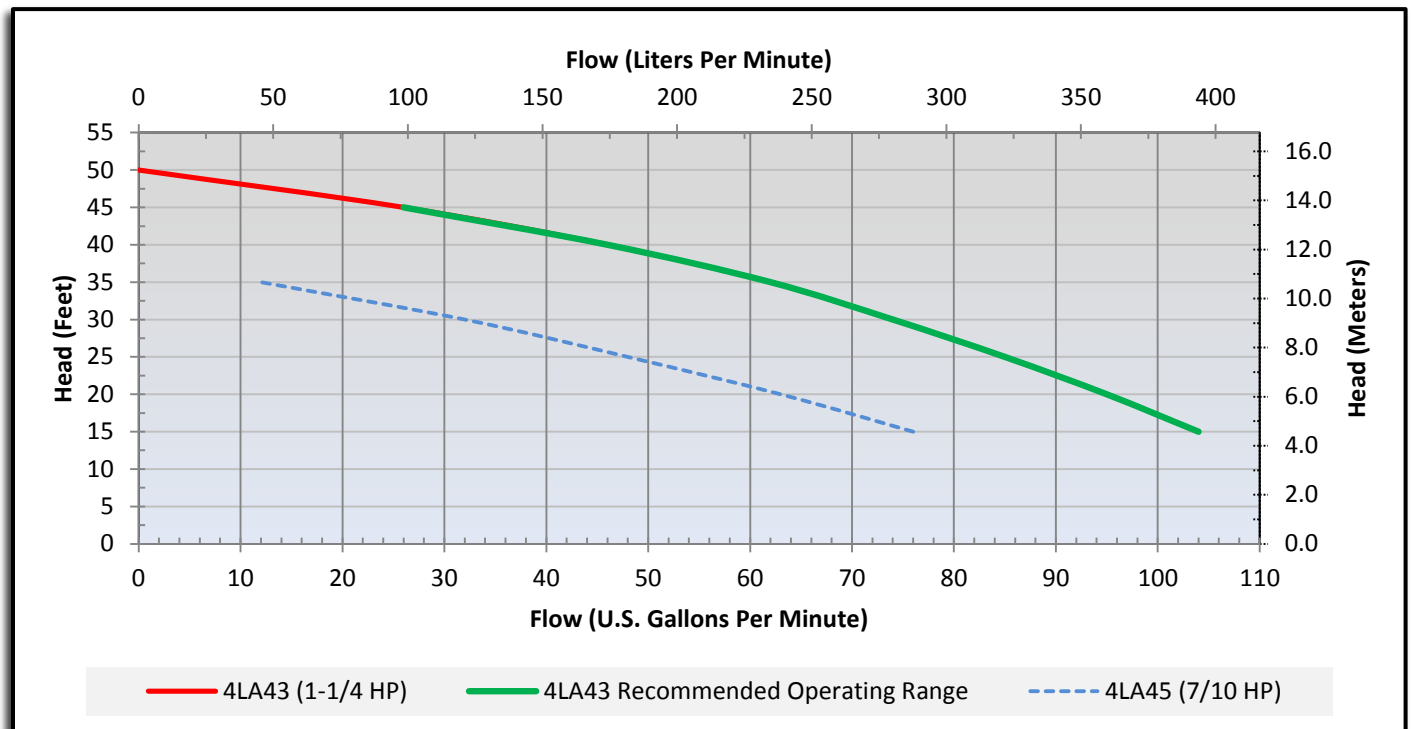

**WARNING:** Use only with nonflammable liquids compatible with pump component materials and in nonflammable/non-explosive atmospheres.

Call or visit your local branch or go to [granger.com/dayton](http://granger.com/dayton) for complete product line information



Find it at Grainger.

© 2013 W.W. Grainger, Inc.