

DAYTON AIR-OPERATED DOUBLE DIAPHRAGM PUMP DATA SHEET 3HJW5, 3HJW3



Technical Specs

	3HJW5	3HJW3
SHIPPING WEIGHT	79 LBS	79 LBS
MAXIMUM LIQUID TEMPERATURE	180°F (82°C)	180°F (82°C)
INTAKE & DISCHARGE PORTS	1-1/2" PORT, FLANGE	1-1/2" PORT, FLANGE
FLOW	0 - 115 GPM MAX	0 - 120 GPM MAX
MAX AIR SUPPLY PRESSURE	100 PSI (1.4 - 7 KGF/CM ²)	100 PSI (1.4 - 7 KGF/CM ²)
BODY MATERIAL	POLYPROPYLENE	POLYPROPYLENE
LIFT - DRY, WET	18 FT, 28 FT	15 FT, 28 FT
AIR VALVE		
LUBRICATION	NO LUBRICATION REQUIRED	NO LUBRICATION REQUIRED
MANUAL OVERRIDE	YES	YES
LIQUID SIDE		
EASY REPAIR	YES	YES
BALL CHECK VALVE	EPDM	PTFE
O-RINGS	EPDM	PTFE
DIAPHRAGMS	SANTOPRENE®	PTFE

DAYTON AIR-OPERATED DOUBLE DIAPHRAGM PUMP

3HJW5, 3HJW3

Dimensional

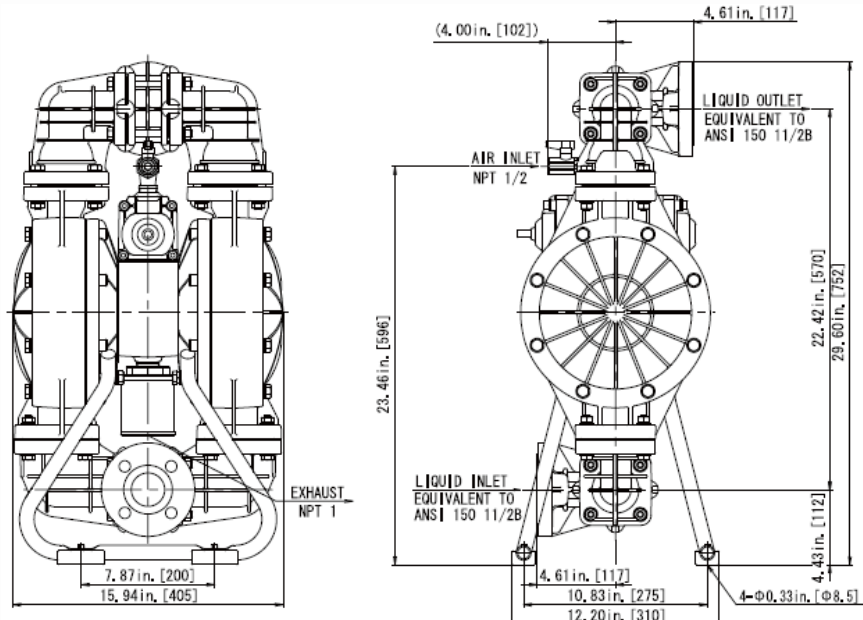

⁽¹⁾ Equivalent to JIS 10K 40A ANSI 150 1-1/2", DIN 40 PN 10 with I.D. 1-1/2" NPT(F)

Performance Curve

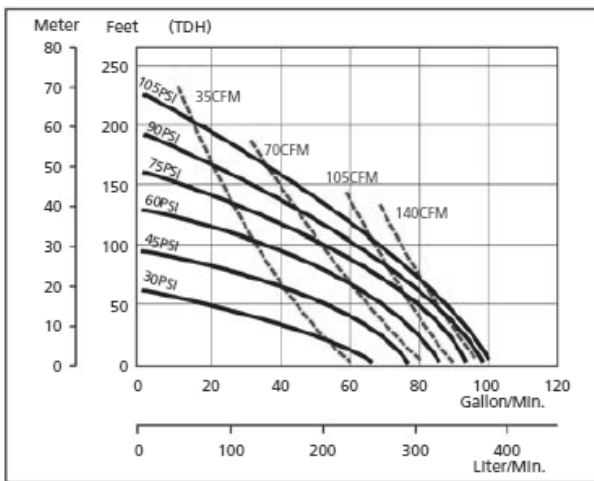

3HJW5

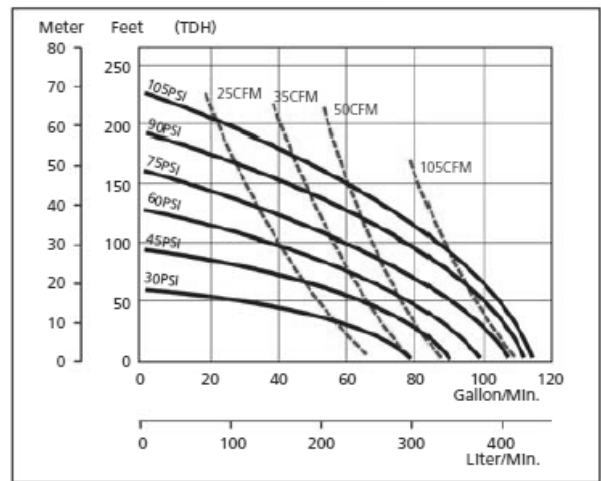

3HJW3

Find it at Grainger.

Call or visit your local branch or go to grainger.com/dayton for complete product line information.

