

PROGRAMMABLE | MULTI-FUNCTION

DIP-SWITCH | DIGITAL-SET | TD-8 SERIES



- ◆ Sixteen user-selectable modes in one unit
- ◆ DIP-Switches for accurate digital set of time delay & selection of function
- ◆ 50ms - 10,230 hours programmable time delay (Single Mode functions only)
- ◆ Uses industry-standard 8 or 11 pin octal socket
- ◆ Pilot duty rating



with appropriate socket



Better. By Design.

800.238.7474

WWW.MACROMATIC.COM

SALES@MACROMATIC.COM

The TD-881 Series offers the digital-set accuracy of DIP-switch setting as well as the flexible programmability of a multi-function and multi-time range relay. These products provide an easy and accurate method to select any of 16 time delay functions and any time delay between 50ms and 10,230 hours (310 hours maximum for Dual Mode functions). Programming is accomplished through the use of two 10-position DIP-switches. This product can literally replace hundreds of different catalog numbers, thereby reducing inventory requirements.

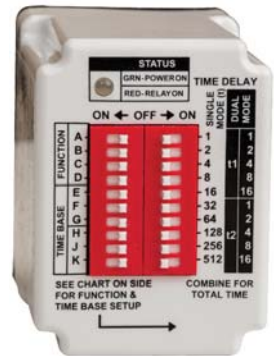

MULTI-FUNCTION ■ (16 Functions in One Unit)

Single Mode

- ◆ On Delay
- ◆ Interval On
- ◆ Flasher (OFF 1st)
- ◆ Flasher (ON 1st)
- ◆ Off Delay *
- ◆ Single Shot *
- ◆ Watchdog *
- ◆ Single Shot (Trailing Edge) *
- ◆ Triggered On Delay *

Dual Mode

- ◆ Repeat Cycle (OFF 1st)
- ◆ Repeat Cycle (ON 1st)
- ◆ Delayed Interval
- ◆ Triggered Delayed Interval *
- ◆ On/Off Delay *
- ◆ Single Shot-Flasher *
- ◆ On Delay/Flasher

* These are the only functions requiring use of the Control Switch shown in Wiring Diagrams below.

OUTPUT	INPUT VOLTAGE	PRODUCT NUMBER	WIRING/SOCKETS
11 Pin DPDT	120V AC/DC 12V DC 24V AC/DC 240V AC	TD-88122 TD-88126 TD-88128 TD-88121	11 PIN OCTAL 70170-D DIAGRAM 121
8 Pin SPDT	120V AC/DC 12V DC 24V AC/DC 240V AC	TD-88162 TD-88166 TD-88168 TD-88161	8 PIN OCTAL 70169-D DIAGRAM 169

■ See "Definitions of Timing Functions".

Sockets & Accessories available

Build your Time Delay Relays with the [Online Product Builder](#)

TD-8 SERIES

DIP-SWITCH | DIGITAL-SET

PROGRAMMING FUNCTION & TIME DELAY

(TD-881 Series Multi-Function Only)

Programming is accomplished through the use of two 10-position DIP-switches. Switches A-D of the left-mounted DIP-switch are used to select a function (see the descriptions of how each function operates in "Definition of Timing Functions" in this catalog). Switches E, F & G of the same DIP-switch are used to select the time base (t) for single mode functions and (t1) for dual mode functions. Switches H, J & K are used to select the time base (t2) for dual mode functions. A convenient chart is on the side of the product to clearly illustrate how to set both the function and time base.

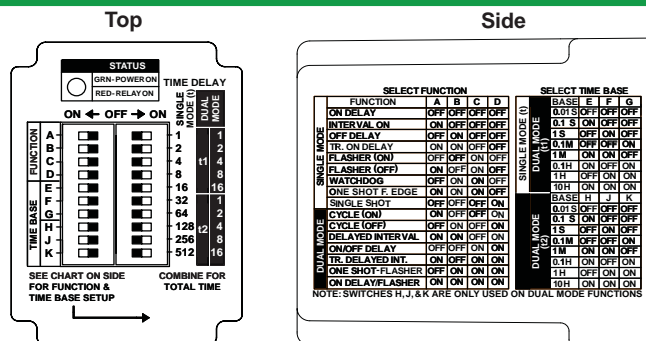

The right-mounted 10-position DIP-switch is used to select the time delay within the time base or bases selected with switches E-K from the first DIP-switch. Each position on the right-mounted DIP-switch is marked with a time increment. The required delay, (t) for single mode functions or (t1) and (t2) for dual mode functions, is selected by moving the switch of each increment to the ON position and adding their corresponding values. NOTE: Dual mode functions can either have the same or different (t1) and (t2) times as well as different time bases. NOTE: Switches H, J, & K are only used on dual mode functions and are not used for single mode functions.

LED Indicator: Green ON--Power, Red ON--Relay Energized

For more information, see www.macromatic.com/onoff.

APPLICATION DATA

Voltage Tolerance:

AC Operation: +10/-15% of nominal at 50/60 Hz.
DC Operation: +10/-15% of nominal.

Load (Burden): 2 VA

Setting Accuracy:

Constant Voltage & Temperature w/i specifications:
±0.1% of set time or ±50ms, whichever is greater
For Variable Voltage & Temperature w/i specifications:
±1% of set time or ±50ms, whichever is greater

Repeat Accuracy:

Constant Voltage & Temperature w/i specifications:
±0.1% of set time or ±0.02 seconds, whichever is greater
For Variable Voltage & Temperature w/i specifications:
±1% of set time or ±0.02 seconds, whichever is greater

Reset Time:

All Functions Triggered by a Control Switch: 0.04 Seconds
All Other Functions: 0.1 Seconds

Start-up Time:

(Time from when power is applied until unit is timing)
0.05 Seconds for all units

Maintain Function Time:

(Time unit continues to operate after power is removed)
0.01 Seconds for all units

Insulation Voltage: 2,000 volts

Temperature: Operating: -28° to 65°C (-18° to 149°F)
Storage: -40° to 85°C (-40° to 185°F)

Output Contacts:

DPDT 10A @ 240V AC/30V DC,
1/2HP @ 120/240V AC (N.O.), 1/3HP @ 120V AC (N.C.)
B300 & R300; AC15 & DC13

Life:

Mechanical: 10,000,000 operations
Full Load: 100,000 operations

Compatibility:

Using a solid state switch to initiate the time sequence is acceptable. See www.macromatic.com/leakage or contact Macromatic for information regarding leakage current limits and other solid state design considerations.

Control Switch Triggered Units:

Minimum required trigger switch closure time is 0.05 seconds.

Approvals:

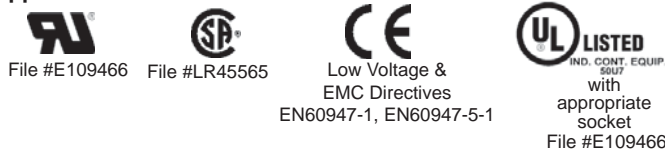

DIMENSIONS

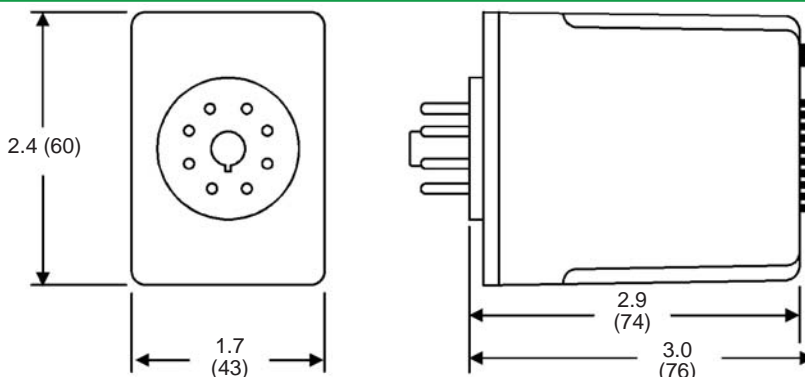

All Dimensions in Inches (Millimeters)