

Document Number	Revision	Revision Date	Product Date Code Beginning With
L4282	Rev. C	01/2022	C

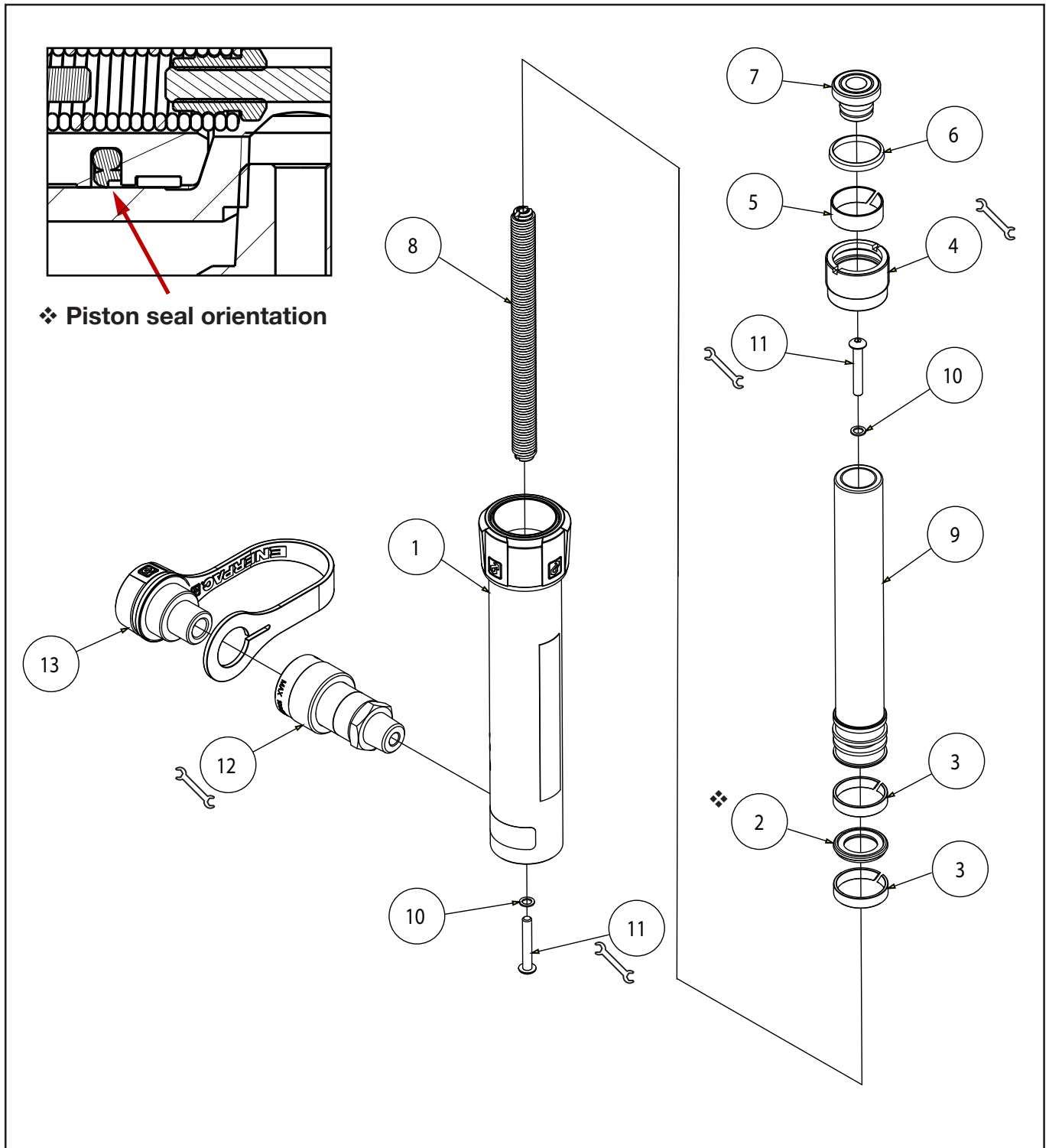

Figure 1, RC Hydraulic Cylinder, 5 Ton

### Repair Parts List, Figure 1

Item	Description	Qty	RC51	Qty	RC53	Qty	RC55	Qty	RC57	Qty	RC59
1	Base	1	N/A	1	N/A	1	N/A	1	N/A	1	N/A
2	Piston Seal	1	▲ ●	1	▲ ●	1	▲ ●	1	▲ ●	1	▲ ●
3	Wear Band, Plunger	1	▲ ★	2	▲ ★	2	▲ ★	2	▲ ★	2	▲ ★
4	Stop Ring	1	RC5044	1	RC5044	1	RC5044	1	RC5044	1	RC5044
5	Wear Band, Stop Ring	1	▲ *	1	▲ *	1	▲ *	1	▲ *	1	▲ *
6	Wiper	1	▲ ✖	1	▲ ✖	1	▲ ✖	1	▲ ✖	1	▲ ✖
7	Saddle Assembly	1	A53G	1	A53G	1	A53G	1	A53G	1	A53G
8	Spring Assembly	1	RC5K31	1	RC5K32	1	RC5K33	1	RC5K34	1	RC5K35
9	Plunger	1	RC51040	1	RC53040	1	RC55040	1	RC57040	1	RC59040
10	Copper Gasket	2	▲ ■	2	▲ ■	2	▲ ■	2	▲ ■	2	▲ ■
11	Screw, #10-32 UNF x 1.25 inch Lg.	2	▲ ■	2	▲ ■	2	▲ ■	2	▲ ■	2	▲ ■
12	Coupler	1	CR400	1	CR400	1	CR400	1	CR400	1	CR400
13	Dust Cap ▲	1	CD411	1	CD411	1	CD411	1	CD411	1	CD411
N/S	O-ring, coupler	1	▲	1	▲	1	▲	1	▲	1	▲
N/S	Enerpac Decal	1	▲	1	▲	1	▲	1	▲	1	▲
N/S	Warning Decal	1	▲	1	▲	1	▲	1	▲	1	▲
N/S	O-ring, saddle	1	▲	1	▲	1	▲	1	▲	1	▲
N/S	Thread Protector	1	▲	1	▲	1	▲	1	▲	1	▲

**Notes:**

- ▲ Indicated item included in and available as a part of the Repair Kit RC5NK0
- Indicated item included in and available as a part of the Spring Assembly
- Indicated item included in and available as packs of 10 units in Seal Kit RC5NKS (see below)
- ★ Indicated item included in and available as packs of 10 units in Wear Band Kit Plunger RC5NKB1 (see below)
- \* Indicated item included in and available as packs of 10 units in Wear Band Kit Stop Ring RC5NKB2 (see below)
- ✖ Indicated item included in and available as packs of 10 units in Wiper Kit RC5NKW1 (see below)

●★✖ Kits only available in America



Item nr.	Torque/ remark
4	Secure with Loctite 222 and torque to 70-90 in-lbs [7.9-10.2 Nm]
11	Torque to 40-50 in-lbs [3.5-5.5 Nm]
12	Torque to 40-60 ft-lbs [54-81 Nm]
	Use Loctite 545 or Teflon Tape