

Please read and save these instructions. This heater must be installed and serviced by trained gas installation and service personnel only! Read carefully before attempting to assemble, install, operate or maintain the product described. Protect yourself and others by observing all safety information. Failure to comply with instructions could result in personal injury and/or property damage! Retain these instructions for future reference.

Dayton® High-Intensity Heaters

Description

Dayton high-intensity heaters become highly efficient generators of infrared radiation by heating a ceramic refractory material to incandescence. The principal operation is to pass a gas-air mixture through a perforated ceramic refractory, and ignite it on the refractory surface. This causes the ceramic material to be heated to approximately 1780°F and generate large amounts of infrared radiation that may be directed anywhere heat is desired. Infrared radiation heats people and objects it strikes and not the intervening air. Included is a direct spark ignition system, manifold pressure tap, porous ceramic grids, a polished aluminum reflector and a chain set for hanging the heater. Typical applications are loading docks, warehouses, service garages, factories, aircraft hangars, etc.

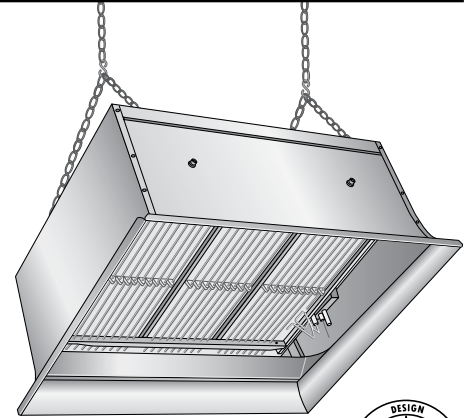

⚠ WARNING



Improper installation, adjustment, alteration, service or maintenance can cause property damage, injury or death. Read and understand the installation, operating and maintenance instructions thoroughly before installing or servicing this equipment.

This heater must be installed and serviced by trained gas installation and service personnel only. Failure to comply could result in personal injury, asphyxiation, death, fire and/or property damage.

⚠ WARNING



In locations used for the storage of combustible materials, signs must be posted to specify the maximum permissible stacking height to maintain the required clearances from the heater to the combustibles. Signs must either be posted adjacent to the heater thermostats or in the absence of such thermostats, in a conspicuous location.

⚠ WARNING



Not for residential use!

This heater is not approved in any residential application. This includes (but is not limited to) the home, living quarters, attached garages, etc. Installation in residential indoor spaces may result in property damage, serious injury or death.

For Your Safety If you smell gas:

- Do not try to light any appliance.
- Do not touch any electrical switch.
- Do not use any phone in your building.
- Immediately call your gas supplier from a neighbor's phone.
- Follow the gas supplier's instructions.
- If you cannot reach your gas supplier, call the fire department.

Keep these instructions for future reference.

Dayton® High Intensity Heaters

ENGLISH

1.0 Safety **3**

- Safety Symbols 3
- Applications 3
- Clearance to Combustibles 4
- Standards, Certifications and Government Regulations 6
- Heater Dimensions 7
- Safety Signs and Labels 8

2.0 Installation **9**

- Design 9
- Heater Placement 10
- Heater Mounting 12
- Ventilation 13
- Gas Supply 14
- Electrical Requirements and Diagrams 17

3.0 Operation **19**

4.0 Maintenance **20**

- Troubleshooting Guide 21
- Heater Assembly Components 22
- Parts Listing 23

5.0 Limited Warranty **24**

Models 3E132E thru 3E134E, 3E460C thru 3E462C, 5VD57 thru 5VD66, 3VH34 thru 3VH37

E
N
G
L
I
S
H

1.0 Safety

⚠ WARNING



Improper installation, adjustment, alteration, service or maintenance can cause property damage, serious injury or death. Read and understand the installation, operating and maintenance instructions thoroughly before installing or servicing this equipment. Only trained, qualified gas installation and service personnel may install or service this equipment.

Safety Symbols

Safety is the most important consideration during installation, operation and maintenance of the infrared heater. You will see the following symbols and signal words when there is a hazard related to safety or property damage.

⚠ WARNING

Warning indicates a potentially hazardous situation which, if not avoided, could result in death or injury.

⚠ CAUTION

Caution indicates a potentially hazardous situation which, if not avoided, could result in minor or moderate injury.

NOTICE

Notice indicates a potentially hazardous situation which, if not avoided, could result in property damage.

Applications

This is not an explosion proof heater. Consult your local fire Marshall, insurance carrier and other authorities for approval of the proposed installation.

Commercial / Industrial (Indoor Use Only)

Infrared heaters are designed and certified for use in industrial and commercial buildings such as warehouses, manufacturing plants, aircraft hangars and vehicle maintenance shops. For maximum safety, the building must be evaluated for potential hazards before installing the heater system. A critical safety factor to consider before installation is the clearance to combustibles.

Residential

This heater is **NOT** approved for use in any residential application. This includes, but not limited to, attached garages, living quarters, solariums, etc. Consult the local fire marshal and/or insurance provider if unsure of your application.

⚠ WARNING



Not For Residential Use.

Installation of an infrared heater system in residential indoor spaces may result in property damage, serious injury or death.

Dayton® High Intensity Heaters

Clearance to Combustibles

WARNING



Placement of explosive objects, flammable objects, liquids and vapors close to the heater may result in explosion, fire, property damage, serious injury or death. Do not store, or use, explosive objects, liquids and vapor in the vicinity of the heater.



Failure to comply with the published clearances to combustibles could result in personal injury, death and/or property damage.

Hazards Include:

For maximum safety the building must be evaluated for hazards before installing the heater system. Examples include, but are not limited to:

- Gas and electrical lines
- Combustible and explosive materials
- Chemical storage areas
- Areas of high chemical fume concentrations
- Provisions for accessibility to the heater
- Adequate clearances around air openings
- Combustion and ventilating air supply
- Vehicle parking areas
- Vehicles with lifts or cranes
- Storage areas with stacked materials
- Lights
- Sprinkler heads (see important note on p. 9).
- Overhead doors and tracks
- Dirty, contaminated environment

CAUTION



Signs shall be posted specifying the maximum permissible stacking height in order to maintain clearances to combustibles.

A critical safety factor to consider before installation is the clearances to combustibles. Clearance to combustibles is defined as the minimum distance you must have between the infrared surface, or reflector, and the combustible item. Considerations must also be made for moving objects around the infrared heater. The following is a partial list of items to maintain clearances from:

Combustible Items Include:

- Wood
- Paper
- Fabric
- Chemicals
- Wall or roof insulation

Moving Objects Include:

- Overhead doors
- Vehicles on lifts
- Cranes
- Hoists
- Car wash equipment

The stated clearance to combustibles represents a surface temperature of 90°F (32°C) above room temperature. Building materials with a low heat tolerance (such as plastic, vinyl siding, canvas, tri-ply, etc.) may be subject to degradation at lower temperatures. It is the installer's responsibility to assure that adjacent materials are protected from degradation.

When installing the infrared heater system, the minimum clearances to combustibles must be maintained. These distances are shown in Chart 1.1 and on the heater. If you are unsure of the potential hazards, consult your local fire Marshall, fire insurance carrier or other qualified authorities on the installation of gas fired infrared heaters for approval of the proposed installation.

Models 3E132E thru 3E134E, 3E460C thru 3E462C, 5VD57 thru 5VD66, 3VH34 thru 3VH37

Chart 1.1 - Clearance to Combustibles in Inches (see Figure 1.1)

Model No.	BTU/H	Gas Type	Voltage	Sides	Back	Top	Below/Front
3E132	30,000	Natural	120 VAC	30	18	28	72
3E460	30,000	Propane	120 VAC	30	18	28	72
5VD61	30,000	Natural	24 VAC	30	18	28	72
5VD62	30,000	Propane	24 VAC	30	18	28	72
3E133	60,000	Natural	120 VAC	32	18	40	72*
3E461	60,000	Propane	120 VAC	32	18	40	72*
5VD63	60,000	Natural	24 VAC	32	18	40	72*
5VD64	60,000	Propane	24 VAC	32	18	40	72*
3E134	90,000	Natural	120 VAC	48	30	42	98
3E462	90,000	Propane	120 VAC	48	30	42	98
5VD65	90,000	Natural	24 VAC	48	30	42	98
5VD66	90,000	Propane	24 VAC	48	30	42	98
130,000		N or LP	24 or 120 VAC	48	30	52	120
160,000		N or LP	24 or 120 VAC	50	32	60	132

*This clearance is 80 in. When the heater is fitted with a parabolic reflector.

NOTE: If the heater is mounted beneath a non-combustible surface, a 24 in. minimum top clearance must be maintained from the top of the heater to prevent overheating the controls.

Ensure that building materials with a low heat tolerance (i.e. awnings, fabrics, plastics, sprinklers, insulation, etc.) are protected against degradation. This may require the heater to be mounted at a distance in excess of the published clearances to combustibles. Contact the building material manufacturer.

Figure 1.1 - Clearance to Combustibles Diagram

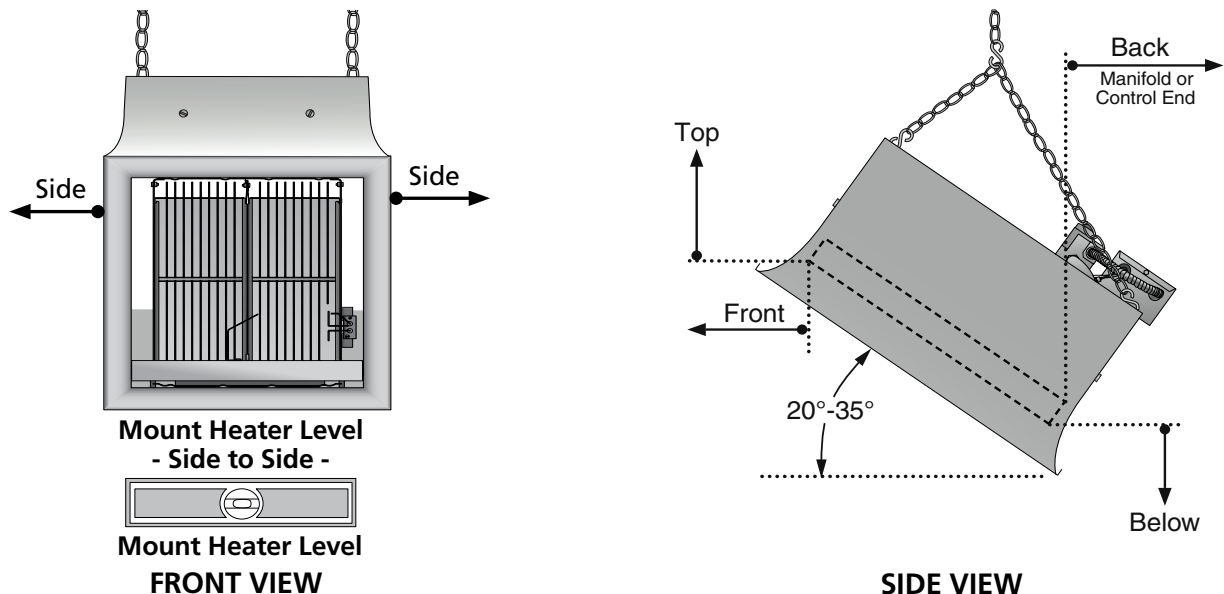

Dayton® High Intensity Heaters

Standards, Certifications and Governmental Regulations

The installation of this heater must comply with all applicable local, state and national specifications, regulations and building codes (contact the local building inspector and/or fire marshall for guidance) before installing the heater system.

In the absence of local codes, the installation must conform to the latest edition of the National Fuel Code ANSI Z223.1 (NFPA 54). Copies of this standard can be viewed or purchased at www.nfpa.org.

Refer to the following Standards and codes for application specific guidelines:

Public Garages:

The installation of this heater in public garages must conform with the Standard for Parking Structures, ANSI/NFPA 88A (latest edition), or the Standard for Repair Garages, ANSI/NFPA 88B (latest edition) and must be at least 8 ft. above the floor.

Aircraft Hangars:

The installation of this heater in aircraft hangars must conform with the Standard for Aircraft Hangars, ANSI/NFPA 409 (latest edition). The heater must be installed at least 10 ft. above the upper wing surfaces and engine enclosures of the highest aircraft which might be stored in the hangar. In areas adjoining the aircraft storage area, the heaters must be installed at least 8 ft. above the floor. The heaters must be located in areas where they will not be subject to damage by aircraft, cranes, moveable scaffolding or other objects.

High Altitude:

The installation of this heater is approved, without modifications, for elevations up to 6,000 ft. MSL (sea level). Contact Dayton for installations above these elevations.

Electrical:

The heater, when installed, must be electrically grounded in accordance with the National Electrical Code ANSI/NFPA 70 (latest edition). Under no circumstances is either the electrical supply line or gas supply line to provide any assistance in the suspension of the heater.

Ventilation:

This heater must be installed in accordance with the requirements set forth in this manual and with the NFPA 54/ANSI Z223.1 National Fuel Gas Code (latest edition). See ventilation requirements on page 14.

Applicable authorities governing the manufacturing or installation of this heater include (but are not limited to) the following organizations:

- NFPA 54/ANSI Z223.1 - National Fuel Gas Code.
- ANSI Z83.19/C2.35 - Gas-fired High Intensity Infrared Heaters.
- ANSI/NFPA 70 - National Electric Code.
- IRSC.

**Models 3E132E thru 3E134E, 3E460C thru 3E462C,
5VD57 thru 5VD66, 3VH34 thru 3VH37**

Figure 1.2 - Heater Dimensions

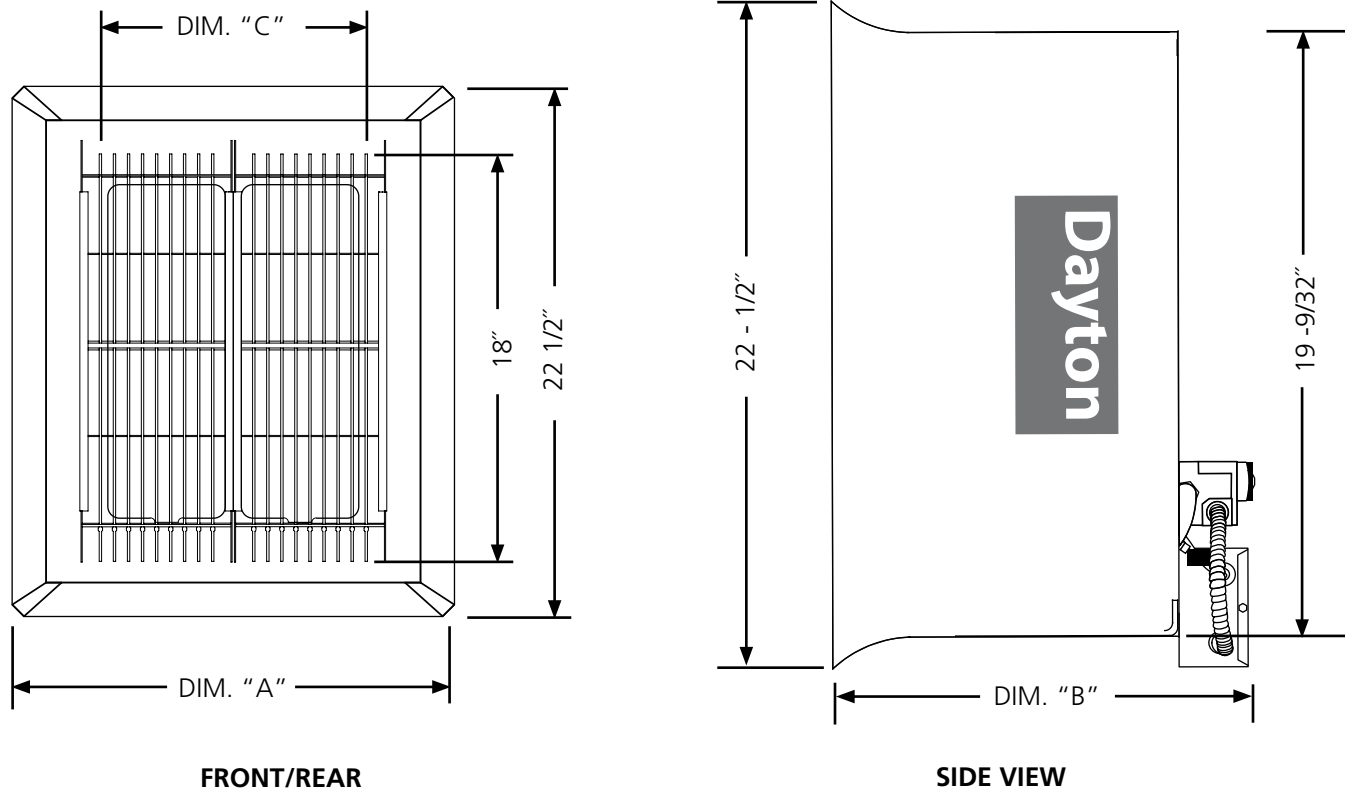

E
N
G
L
I
S
H

Chart 1.2 - Heater Dimensions

MODEL BTU/H	HEATER WIDTH DIM "A"	HEATER DEPTH DIM "B"	RAYHEAD(S) WIDTH DIM "C"	HANGING WEIGHT
30,000	12 3/4"	14 1/4"	5"	18 lbs.
60,000	19 1/8"	15 1/4"	11 1/2"	27 lbs.
90,000	26 5/8"	15 1/4"	18"	36 lbs.

Dayton® High Intensity Heaters

Safety Signs and Labels

It is important to provide warnings to alert individuals to potential hazards and safety actions. ANSI Z83.19a and the National Fuel Gas Code require you to post a sign "specifying the maximum permissible stacking height to maintain the required clearances from the heater to the combustibles" near the heaters thermostat or in absence of such thermostats in a conspicuous location. Signs should state the hazards for the particular application and be legible to the building occupants. Consult the factory or a factory representative for additional information on signage compliance.

Safety warning labels must be maintained on the infrared heater. Illustrations of the safety labels, and their locations, are pictured below.

UNVENTED GAS-FIRED RADIANT HEATER		
FOR INDOOR (Non-Residential) INSTALLATION ONLY. High-Intensity Infrared Heater Class IIIA Permit-required Label		
MODEL NO. 3E461C	INPUT BTUH 60,000	FOR USE WITH LP Gas
Voltage AC: 120VAC - 60Hz	Heater Type: C1	Min. Inlet Pressure for purpose of adjustment 7.0 INCHES W.C.
AMPS - Starting: 0.1	Maximum Inlet Pressure: 14.0 INCHES W.C.	Minimum Mounting Angle: 20 DEGREES
AMPS - Running: 0.1	Minimum Inlet Pressure: 14.0 INCHES W.C.	Maximum Mounting Angle: 35 DEGREES
DESIGN COMPLIES WITH: ANSI Z83.19-2001 GAS-FIRED HIGH-INTENSITY INFRARED HEATER		Serial No.: 09 01 07 0006 A
MANUFACTURED FOR: DAYTON ELECTRIC MFG. CO. MUEL, IL 60714 U.S.A.		

Back Panel

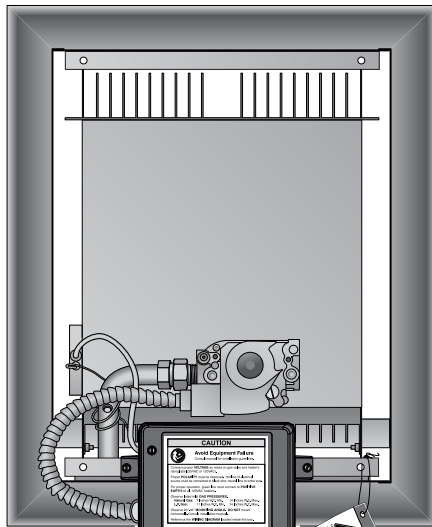

CAUTION

Avoid Equipment Failure

Consult manual for installation guidelines.

Connect proper **VOLTAGE** as noted on gas valve and heater's rating label (25VAC or 120VAC).

Proper **POLARITY** must be observed. Hot line of electrical source must be connected to black wire; neutral line to white wire.

For proper operation, green line must connect to **POSITIVE EARTH** on all 120VAC heaters.

Observe listed inlet **GAS PRESSURES**.

Natural Gas: 7 Inches W.C. Min. 14 Inches W.C. Max.
L.P. Gas: 11 Inches W.C. Min. 14 Inches W.C. Max.

Observe 20°-35° **MOUNTING ANGLE**. **DO NOT** mount horizontally. Consult installation manual.

Reference the **WIRING DIAGRAM** located inside this box.

F/N: LLDRO02

Bottom Panel

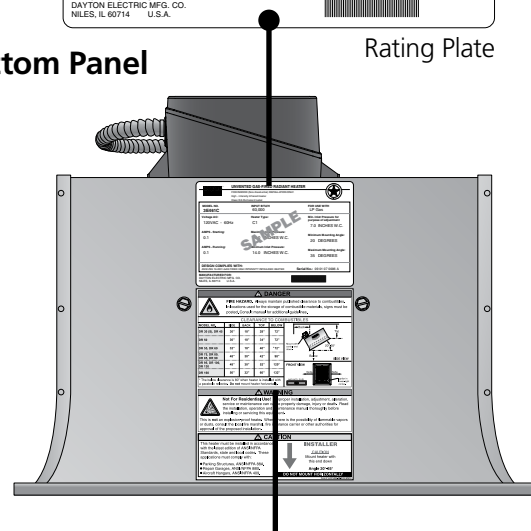

Rating Plate

DANGER

Avoid Serious Injury, Death or Property Damage.
Maintain Clearances to Combustible to Prevent the Risk of Fire.

Clearance to combustibles must be maintained at all times in order to prevent the ignition of combustible materials. In locations used for the storage of combustible materials, signs must be posted to specify the maximum permissible stacking height to maintain the required clearances from the heater to the combustibles. Signs must either be posted adjacent to the heater's thermostats or in the absence of such thermostats, in a conspicuous location. Clearances are provided on the heater's safety label and in the heater's Installation, Operation and Maintenance manual, Product installation and operation must comply with applicable standards, codes and regulations. Post this tag adjacent to the heater's thermostat or controls before operating the heater.

- INSTALLER: READ AND POST THIS NOTICE -

F/N: LL01 - Clearance Safety Tag
(Affix adjacent to heater's thermostat)

DANGER

FIRE HAZARD. Always maintain published clearance to combustibles. In locations used for the storage of combustible materials, signs must be posted. Consult manual for additional guidelines.

CLEARANCE TO COMBUSTIBLES

MODEL NO.	SIDE	BACK	TOP	BELOW
30,000 BTUH 3E132, 3E134 5VD51, 5VD52	30"	18"	28"	72"
60,000 BTUH 3E133, 3E461 5VD53, 5VD54	32"	18"	40"	72"
90,000 BTUH 3E134, 3E462 5VD55, 5VD56	48"	30"	42"	98"
130,000 BTUH 3E463	48"	30"	52"	120"
160,000 BTUH 3E464	50"	32"	60"	132"

Do not mount heater horizontally.

WARNING

Not For Residential Use! Improper installation, adjustment, alteration, service or maintenance can cause property damage, injury or death. Read the installation, operation and maintenance manual thoroughly before installing or servicing this equipment.

This is not an explosion-proof heater. Where there is the possibility of flammable vapors or dusts, consult the local fire marshal, fire insurance carrier or other authorities for approval of the proposed installation. Always maintain minimum ventilation requirements.

CAUTION

This heater must be installed in accordance with the latest edition of ANSI/NFPA Standards, state and local codes. These applications must comply with:

- Parking Structures, ANSI/NFPA 88A.
- Repair Garages, ANSI/NFPA 88B.
- Aircraft Hangars, ANSI/NFPA 409.

INSTALLER

CAUTION

Mount heater with this end down

Angle 20°-35°

DO NOT MOUNT HORIZONTALLY

Form # LLDCL00-08-0316 (08/16)

F/N: LLDCL002

Models 3E132E thru 3E134E, 3E460C thru 3E462C, 5VD57 thru 5VD66, 3VH34 thru 3VH37

2.0 Installation

⚠ WARNING



Read and understand, the installation, operating and maintenance instructions thoroughly before installing or servicing this equipment.

Only trained, qualified gas installation and service personnel may install or service this equipment.

Design

To ensure a safe, properly designed heating system, a layout should be developed for the correct placement of the infrared heater(s). Aside from safety factors such as clearance to combustibles (see Chart 1.1 on page 5), you should take into consideration the environment (e.g., cold/drafty, average, protected), heat coverage (sq. ft.) needed, heater centers, the distance behind a person or work station(s), and exhaust path. Also, the effective infrared surface temperature of a person or object may be diminished with wind above 5 mph. Wind barrier(s) may be required. Most importantly, clearance to combustibles must always be maintained! Refer to hazards on page 4.

This installation manual, along with national, state, provincial and local codes, address these issues. It is critical that you read, understand and follow all guidelines and instructions. Always inspect and evaluate the mounting conditions, space for exhaust, gas supply and wiring.

Perimeter mounting of infrared heaters provides the most effective distribution of heat. The recommended spacing between the heaters is shown in Chart 2.1. Add additional heaters in the center of the space when heaters are spaced further than the recommended distance (see Figure 2.1).

⚠ CAUTION

This heater cannot be used in a building with an uninsulated roof or condensation problems can occur.

Factory recommended mounting heights (see Chart 2.2) are listed as a guideline. If infrared heaters are mounted to low or to high, they may result in discomfort or lack of heat. The factory generally recommends observing the recommended mounting heights to optimize comfort conditions. However, certain applications such as spot heating, freeze protection, outdoor patio heating or very high ceilings may result in the heaters being mounted outside of the recommended mounting heights.

When heated, materials high in hydrocarbons (solvents, paint thinner, mineral spirits, formaldehydes, etc.) can evaporate. This may result in odors or fumes being emitted into the environment. To correct this problem, clean the area and/or introduce additional ventilation. Heaters installed and serviced in accordance with the installation manual do not emit foul odors into the environment.

IMPORTANT: Fire sprinkler heads must be located at an appropriate distance from the heater. This distance may exceed the published clearance to combustibles (see Chart 1.1). Certain applications will require the use of high temperature sprinkler heads or relocation of the heaters.

⚠ CAUTION

Fire sprinkler systems containing propylene glycol, antifreeze or other potentially flammable substances shall not be used in conjunction with this heater without careful consideration for and avoidance of inadvertent discharge hazards. For further information consult NFPA 13. Always observe applicable state and local codes.

Dayton® High Intensity Heaters

Chart 2.1 - Recommended Mounting Heights and Distances for "Total Area" Heating

BTU/H Input	Mounting Heights Dim. A		Distance Between Heaters Dim. B (ft.)	Distance Between Heater Rows Dim. C (ft.)	Distance Between Heater and Wall (ft.)
	30° Angle Standard Reflector (ft.)	30° Angle Parabolic Reflector (ft.)			
30,000	12-14	12-15	8-30	10-70	6
60,000	14-16	18-21	15-43	15-90	12
90,000	16-18	21-25	20-55	20-110	12

Figure 2.1 - Total Area Heating Sample Layout

Perimeter mounting

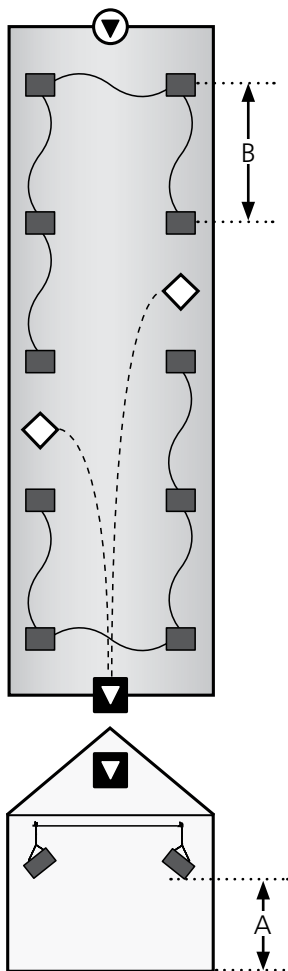

Perimeter and center row mounting

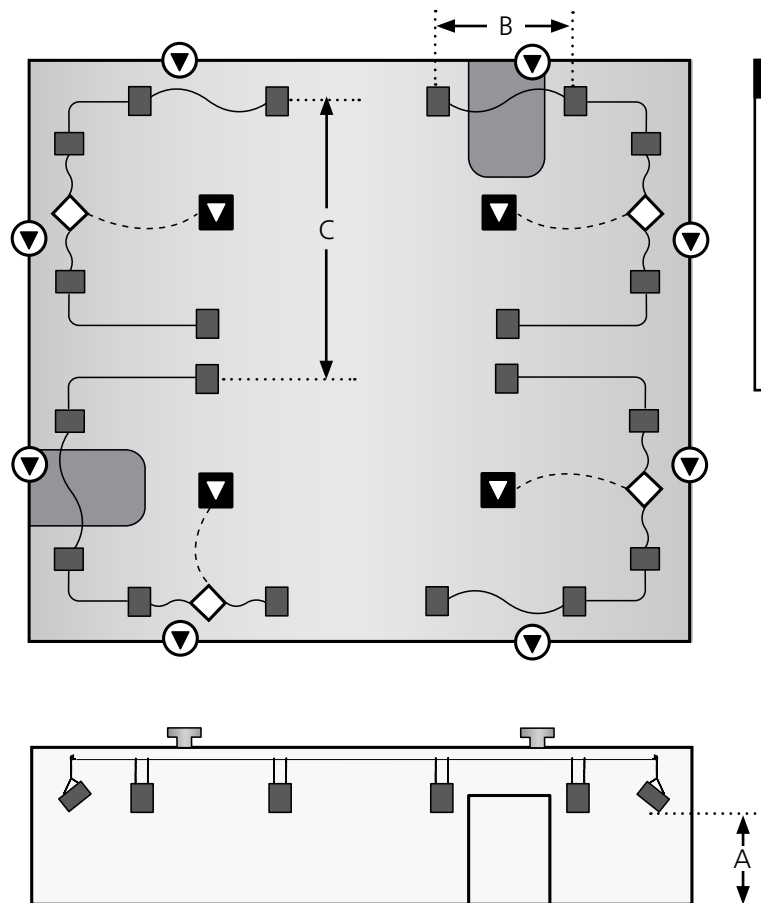

Key	
	Infrared heater
	Thermostat
	Air intake louver
	Exhauster

E
N
G
L
I
S
H

Models 3E132E thru 3E134E, 3E460C thru 3E462C, 5VD57 thru 5VD66, 3VH34 thru 3VH37

Chart 2.2 - Recommended Mounting Heights and Distances for "Spot" Heating

Model & Input	Type of Area (Surroundings)	Approx. Area Covered	Approx. Coverage (sq. ft.)	Recommended Mounting Height Std. Reflector (Dim. A)	Distance Behind Person or Work Station (Dim. B)	Centers for Full Coverage (Spot & Area) Htg. Only
DR-30 30,000 BTU/h	Cold/Drafty	10' x 10'	100	9' to 10'	4'	10'
	Average	12' x 12'	144	10' to 12'	5'	12'
	Protected/Insul.	14' x 14'	196	12' to 14'	6'	14'
DR-45 45,000 BTU/h	Cold/Drafty	12' x 12'	144	10' to 12'	5'	12'
	Average	14' x 14'	196	12' to 14'	6'	14'
	Protected/Insul.	16' x 16'	256	14' to 16'	7'	16'
DR-60 60,000 BTU/h	Cold/Drafty	16' x 16'	256	12' to 14'	6'	16'
	Average	18' x 18'	324	14' to 16'	7'	18'
	Protected/Insul.	20' x 20'	400	16' to 18'	8'	20'
DR-75 75,000 BTU/h	Cold/Drafty	18' x 18'	324	14' to 16'	7'	18'
	Average	22' x 22'	484	16' to 18'	8'	22'
	Protected/Insul.	26' x 26'	676	18' to 20'	9'	24'
DR-90 90,000 BTU/h	Cold/Drafty	20' x 20'	400	16' to 18'	9'	20'
	Average	24' x 24'	576	18' to 20'	10'	24'
	Protected/Insul.	28' x 28'	784	20' to 22'	11'	26'
DR-95, DR-100 95,000, 100,000 BTU/h	Cold/Drafty	24' x 24'	576	18' to 20'	10'	24'
	Average	28' x 28'	784	18' to 20'	11'	26'
	Protected/Insul.	32' x 32'	1024	20' to 22'	12'	30'
DR-130 130,000 BTU/h	Cold/Drafty	26' x 26'	676	18' to 20'	11'	26'
	Average	30' x 30'	900	18' to 20'	12'	28'
	Protected/Insul.	35' x 35'	1225	20' to 22'	13'	32'
DR-160 160,000 BTU/h	Cold/Drafty	28' x 28'	784	20' to 22'	12'	28'
	Average	35' x 35'	1225	24' to 26'	16'	32'
	Protected/Insul.	40' x 40'	1600	28' to 30'	20'	35'

E
N
G
L
I
S
H

Figure 2.2 - Spot Heater Heights

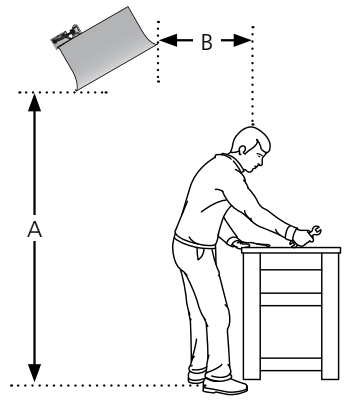

Dayton® High Intensity Heaters

Heater Mounting

⚠ WARNING



Failure to maintain minimum clearance to combustibles may result in fire and/or explosion, property damage, serious injury or death. Always maintain minimum clearances and post clearance safety limit signs where needed. Signs should state the hazards for the particular application and be legible to the building occupants. Consult the factory or a factory representative for additional information on signage compliance.

The heater can be suspended with chains or rigid threaded rod. Local codes, or conditions that would cause the unit to move (e.g., wind drafts, blowers, crane rails, etc.), may require rigid threaded rod. Consult all applicable codes before installation.

⚠ WARNING



Improper suspension of the infrared heater may result in collapse and being crushed. Always suspend from a permanent part of the building structure that can support the total force and weight of the heater.

⚠ WARNING



Avoid Equipment Failure.

Important: The heater must be level from side to side (front view) and between 20° and 35° from horizontal (side view). The spark ignitor, manifold and controls must be located on lower end.

Installing this unit on any other angle or in a horizontal position will cause damage to the heater's controls. See figure 2.3.

Figure 2.3 • Heater Mounting and Orientation

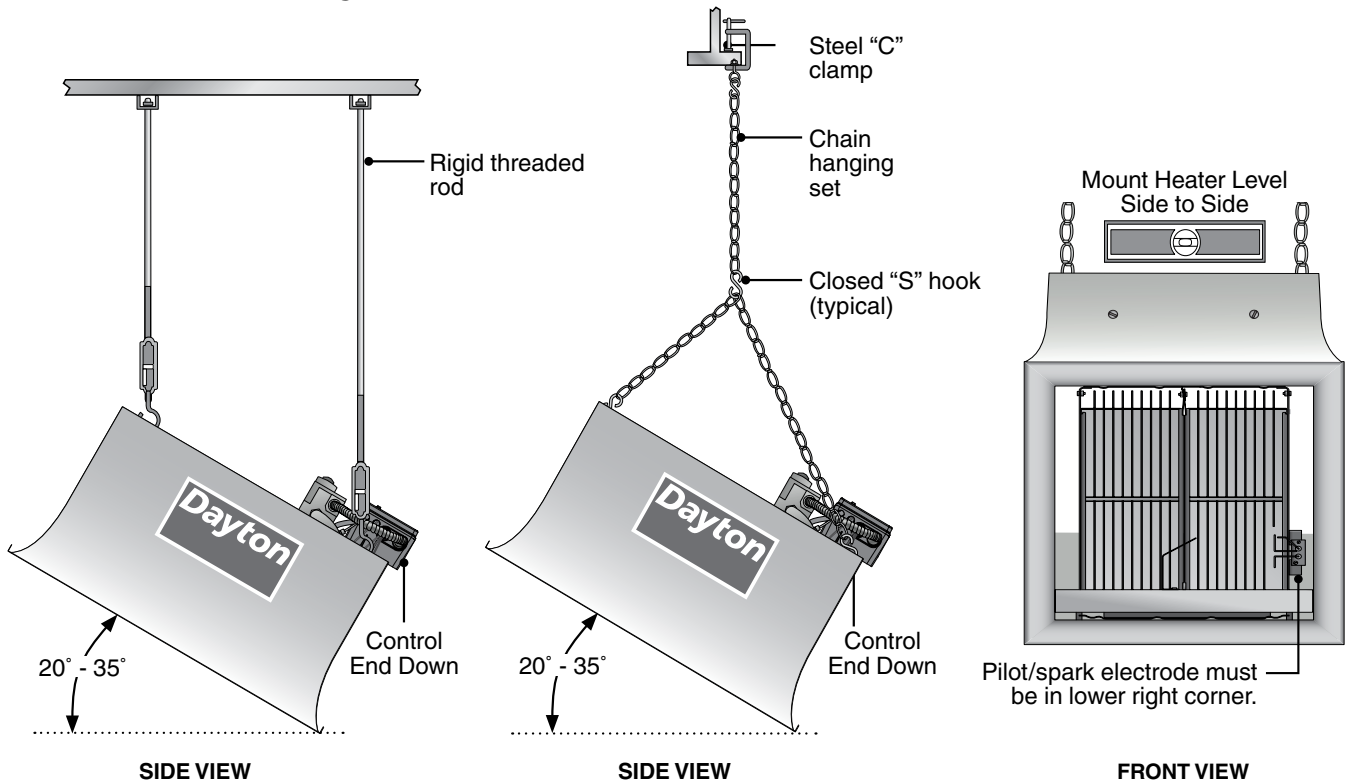

E
N
G
L
I
S
H

Models 3E132E thru 3E134E, 3E460C thru 3E462C, 5VD57 thru 5VD66, 3VH34 thru 3VH37

Ventilation

⚠ WARNING



Insufficient ventilation may result in property damage, health problems, carbon monoxide poisoning, injury or death.

It is required that the upper levels of the space to be heated are properly ventilated to supply combustion air to the heaters and to sufficiently dilute the products of combustion. It is also required that the flue discharge area is kept clear of gas piping and electrical wiring (see Figure 2.4).

This infrared heater must be vented in accordance with national, state, provincial and local codes and the guidelines in this manual. In the United States refer to the latest edition of ANSI Z223.1 (NFPA 54) and in Canada refer to the latest edition of the CAN/CGA B149.1 & B149.2 Standard.

Provisions must also be made to provide sufficient fresh air intake area and exhaust air outlet area. For proper ventilation, a positive air displacement of **4.0 CFM/1000 BTU/h of gas** consumed must be provided.

Where insufficient air movement exists, induced air displacement is required. A balanced system is essential to avoid negative building pressure which causes excessive infiltration, unfavorable drafts and affects combustion efficiency.

Air displacement may be accomplished by either natural or mechanical means. Mechanical exhausters are preferred and typically mounted at high points on the roof where stagnant air accumulates inside the building. For a flat roof, considerations of prevailing winds, high and low pressure areas, and distribution of air movement must be taken into consideration when locating exhausters.

⚠ CAUTION



Ventilate enclosed spaces and buildings according to national, state, provincial and local codes. Failure to provide adequate ventilation may result in equipment malfunctions, condensation and other air quality issues.

Figure 2.4 Hot Flue Discharge

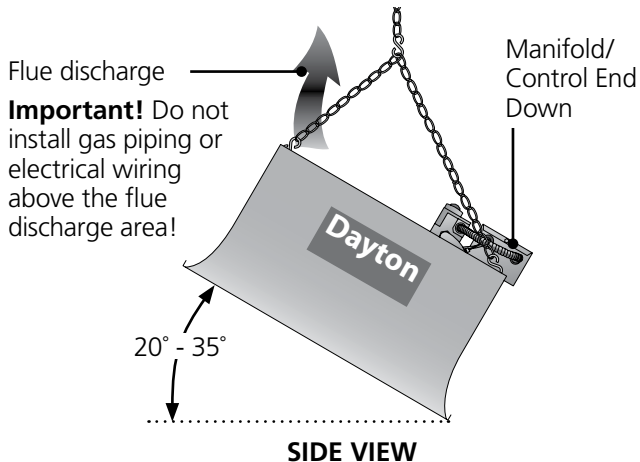

Air distribution is best accomplished by using a number of small exhausters versus one large exhauster. A minimum of **one square inch of inlet area per 1000 Btu/h for combustion air supply** must be provided. Inlet opening in the building should be well distributed (see Figure 2.1) high in the sidewalls and should direct incoming air upward to dilute products of combustion while preventing drafts at lower levels. Inlets are typically 1 to 3 sq. ft.

Local codes may require that mechanical exhaust systems be interlocked with heaters to enable both to function simultaneously (see page 17, Figure 2.6) or allow control of exhausters with a ceiling mounted humidistat.

Dayton® High Intensity Heaters

Gas Supply

⚠ WARNING



Improperly connected gas lines may result in fire, explosion, poisonous fumes, toxic gases, asphyxiation or death. Connect gas lines in accordance to national, state, provincial and local codes.

The gas supply to the infrared heater must be connected and tested in accordance with national, state, provincial and local codes along with the guidelines in the Dayton® High Intensity Heater manual. In the United States refer to the latest edition of the ANSI Z223.1 (NFPA 54) Standard, and in Canada refer to the latest edition of the CAN/CGA B149.2 Standard.

Important! Before connecting the gas supply to the infrared heater(s):

- Check that the gas piping and service has the capacity to handle the load of all heaters being installed, as well as any other gas appliances being connected to the supply line.
- Check that the main gas supply line is of proper diameter to supply the required fuel pressures.
- If utilizing used pipe, verify that its condition is clean and comparable to a new pipe. Test all gas supply lines in accordance with local codes.
- Test and confirm that inlet pressures are correct. Refer to the rating plate for required minimum and maximum pressures (see Chart 2.3). The gas supply pipe must be of sufficient size to provide the required capacity and inlet pressure to the heater (if necessary, consult the local gas company).

Chart 2.3 Manifold Pressure

Type of Gas	Required Manifold Pressure	Minimum Inlet Pressure	Maximum Inlet Pressure
Natural	6.0 Inches W.C.	7.0 Inches W.C.	14.0 Inches W.C.
Propane	10.0 Inches W.C.	11.0 Inches W.C.	14.0 Inches W.C.

Note: Check manifold pressure at the tap located either at the outlet of the gas valve or on the gas manifold pipe. Readings will be above atmospheric pressure during operation.

Pressure Equivalents: 1 inch W.C. equals .058 oz/sq. in. equals 2.49 Mbar.

To connect the gas:

⚠ WARNING



Failure to install, operate or service this appliance in the approved manner may result in property damage, injury or death.

This heater must be installed and serviced by trained gas installation and service personnel only.

The gas outlet must be in the same room as the appliance and accessible. It may not be concealed within or run through any wall, floor or partition.

ENGLISH

Models 3E132E thru 3E134E, 3E460C thru 3E462C, 5VD57 thru 5VD66, 3VH34 thru 3VH37

To connect the gas:

WARNING



Failure to install, operate or service this appliance in the approved manner may result in property damage, injury or death.

WARNING



An approved connector, suitable for the environment of equipment usage, is required. Visible or excessive swaying, flexing and vibration of the gas connections must be avoided to prevent failure. Neither the gas pipe nor the connector shall be placed in the 'flue discharge area'. In no case shall the gas supply support the weight of the heater.

This heater must be installed and serviced by trained gas installation and service personnel only.

The installation of this heater must conform with local building codes or, in the absence of such codes, the National Fuel Code (NFPA 54).

The gas outlet must be in the same room as the appliance and accessible. It may not be concealed within or run through any wall, floor or partition.

1. The DR Series heater is equipped to receive a gas supply line nipple of 1/2" NPT Schedule 40 metallic pipe. All piping must be installed in accordance with the requirements outlined in the National Fuel Gas Code ANSI/Z223.1 (latest edition) or CSA B149.2. Support all gas supply with pipe hangers, metal strapping, or other suitable material. Do not rely on the heater to support the gas pipe.

2. Form the stainless steel flexible connector (field supplied) into a smooth C-shape allowing 12 in. between the flexible connector's end nuts. Figure 2.5 on page 16.

NOTE: Not for use on rigidly mounted heaters.

3. Install a ground joint union with a brass seat and a manual shut off valve adjacent to the unit for emergency shut off and easy servicing of controls. A 1/8" NPT plugged tap that is accessible for a test gauge connection is also recommended.
4. A sediment trap must be installed in the supply line in the lowest spot prior to connecting to the heater. The trap length shall be at least three inches long. Ideally, the trap would be installed as close as possible to the shut off.
5. When connecting piping to the unit, the use of a thread joint compound is required. The thread compound (pipe dope) shall be resistant to the action of propane gas or any other chemical constituents of the gas to be conducted through the piping. Use of Teflon® tape is not permitted.

WARNING



Always use two (2) opposing wrenches to tighten mating pipe connections to prevent excessive torque on the gas valve and manifold pipe. Excessive torque can damage the valve and/or misalign the orifice, resulting in fire, explosion, serious injury or death.

Dayton® High Intensity Heaters

Figure 2.5 • Gas Connection

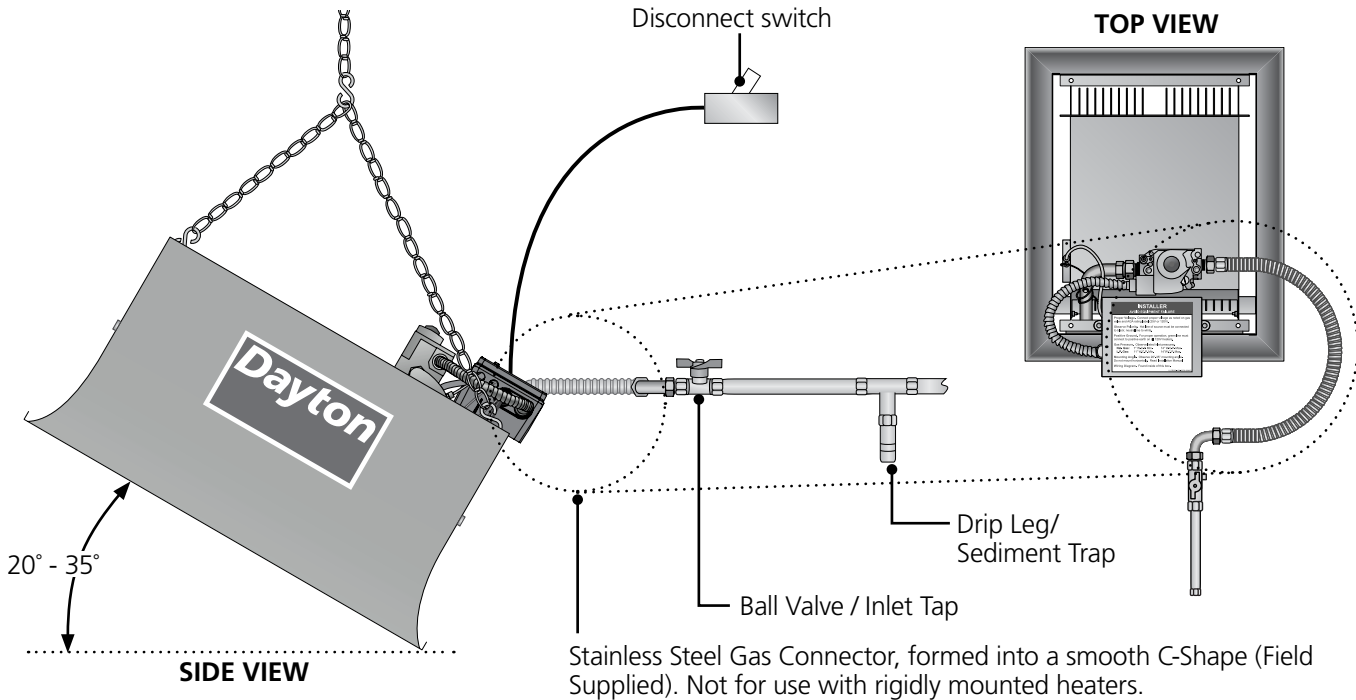

E
N
G
L
I
S
H

Leak Testing

⚠ WARNING



Use a soap solution or equivalent for leak testing. Never test for leak with an open flame. Failure to comply could result in personal injury, property damage or death.

Always leak test final gas assembly for gas leaks according to the procedures outlined in NFPA 54 and all local codes and/or Standards.

For leak testing on pressures below 1/2" PSI

Before leak testing, close the field installed manual shut off valve shown on Figure 2.5 on the supply line to isolate the gas valve from the pressure.

NOTE: All factory installed gas connections have passed an approved leak test.

For leak testing on pressures above 1/2" PSI

When leak testing with pressures above 1/2" PSI (14 inches W.C.), the unit must be isolated from the supply pipe. Close the field installed manual shut off valve, disconnect the supply line to the unit, and temporarily cap the supply line for testing purposes.

⚠ WARNING



Gas pressures to the appliance controls must never exceed 14 inches W.C. (1/2" PSI). Supply pressures greater than 14" W.C. can damage the controls, resulting in personal injury, property damage, or death.

Models 3E132E thru 3E134E, 3E460C thru 3E462C, 5VD57 thru 5VD66, 3VH34 thru 3VH37

Electrical Requirements and Diagrams

⚠ WARNING



Shock hazard. Disconnect power supply before making wiring connections to prevent electrical shock and equipment damage. Any original factory wiring that requires replacement must be replaced with wiring material having a temperature rating of at least 105°C.

All field installed wiring to the unit heater must be done in accordance with the national, state, provincial, local codes and to the guidelines in this manual. In the United States, refer to the most current revisions to the Electrical Code ANSI/NFPA 70 and in Canada refer to the most current revisions to the Canadian Electrical Code CSA C22.1 Part 1. The unit must be electrically grounded according to these codes. Line polarity must be observed when making field connections.

⚠ CAUTION



Avoid Equipment Failure.

Do not install 120VAC to a 24VAC control system.

Before proceeding with electrical connections, ensure that the supply voltage, frequency, phase and current capacity meet the requirements specified on the rating plate. A dedicated line voltage supply with properly sized wire should run directly from the main electrical panel to the heater. The power to the unit must be protected with a circuit breaker appropriate for the load. The unit must be electrically grounded in accordance with local codes, or in their absence, with the latest edition of the National Electrical Code, ANSI / NFPA 70 and/or the Canadian Electrical Code CSA C22.1, latest edition.

Control systems are initiated by either 120 VAC, 24 VAC or millivolt energy. The 120 VAC systems can be used directly from a 120 VAC line. On 24 VAC systems, transformers must be used to supply power of sufficient VA rating for single or multiple connected installations.

Millivolt systems require NO external power, as energy needed to operate the valve is developed by the power-pile generator. Do not use multiple connections, as one thermostat may only control one heater.

For wiring of controls on the unit, see the Figure 2.6 below. It is recommended that the thermostat be installed on the hot side of a fused supply line and have sufficient ampere capacity rating for the heater(s) it will control. The ventilation system may not be controlled separately from the heating system (consult local codes) by the use of a humidistat that closes then the humidity rises. The humidistat control should be installed at roof level. For summer ventilation, a simple on/off switch can be installed at the occupant level.

Figure 2.6 - Typical Field Wiring

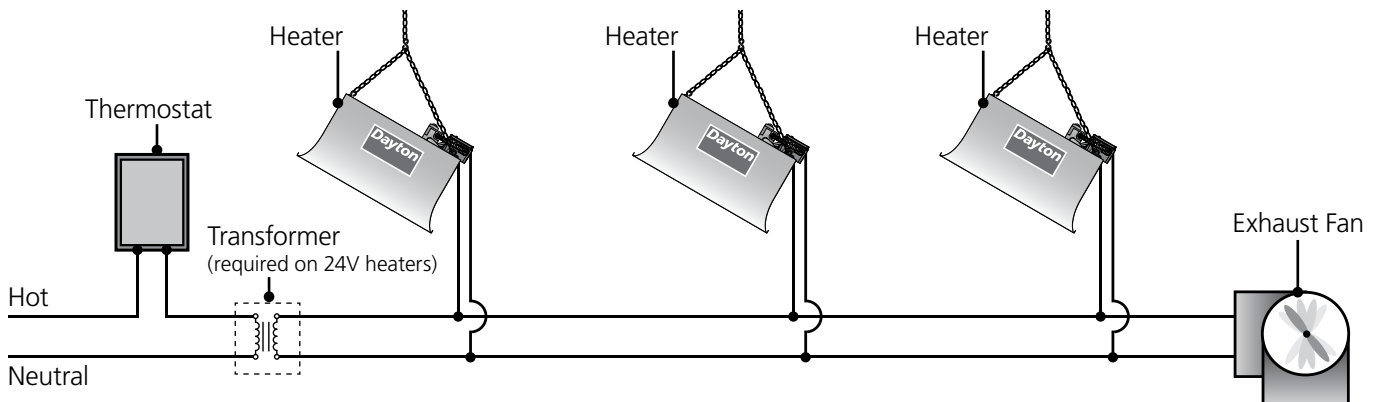

E
N
G
L
I
S
H

Dayton® High Intensity Heaters

Wiring Diagrams

Figure 2.7 - 24 V Schematic (5VD57 thru 5VD66)

- Direct Spark Ignition
- VA Draw: 12
- Amps: .48
- Potted Circuit Board

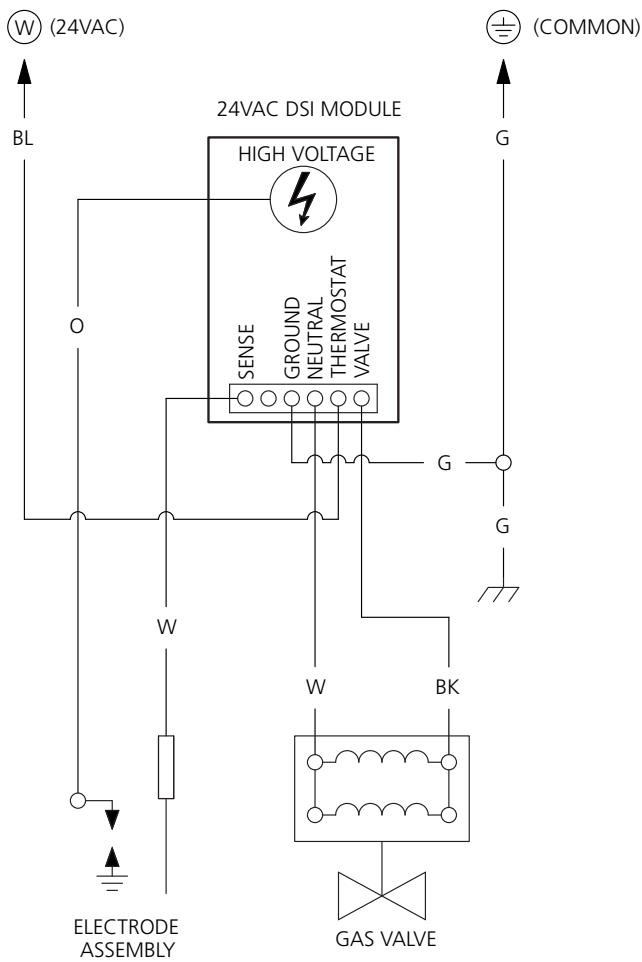
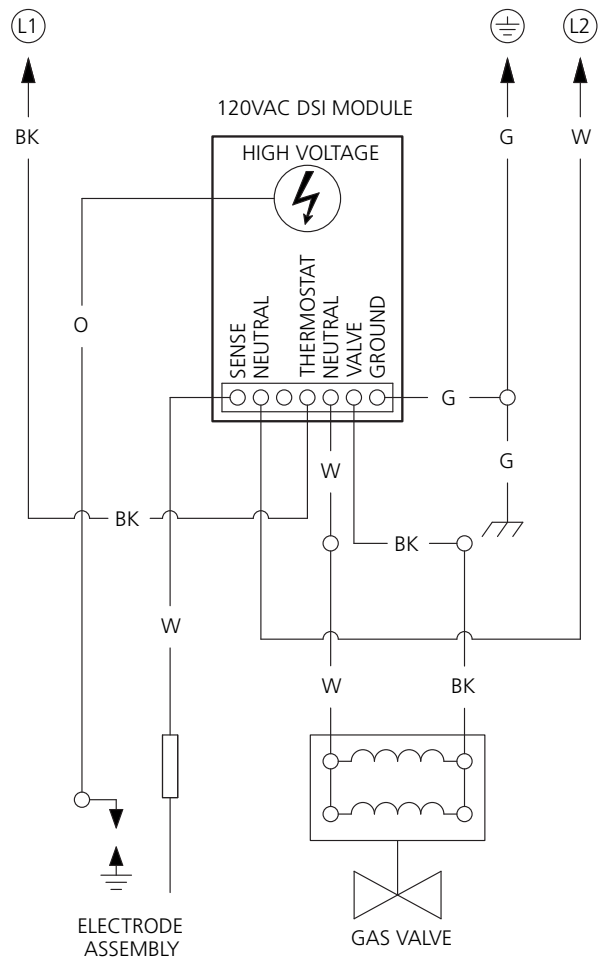

Figure 2.8 - 120 V Schematic (3E132 thru 3E134,
3E460 thru 3E462, 3VH34 thru 3VH37)

- Direct Spark Ignition
- VA Draw: 12
- Amps: .10
- Potted Circuit Board



E
N
G
L
I
S
H

Models 3E132E thru 3E134E, 3E460C thru 3E462C, 5VD57 thru 5VD66, 3VH34 thru 3VH37

3.0 Operation

Upon satisfactory completion of the electrical supply and purging of the gas supply line to the heater(s), follow the lighting instructions on the heater's rating label to put the heater into operation.

Lighting Instructions

1. Rotate the heater's valve knob to the "ON" position.
2. Close electrical circuit (typically the thermostat).
3. If the heater fails to light, turn off gas, open electrical circuit and wait 5 minutes before repeating the above steps.

Shutdown Instructions

1. Open electrical circuit.
2. Rotate the heater's valve knob to the "OFF" position.

⚠ WARNING



Do not attempt to ignite heater by hand. Failure to comply could result in personal injury, property damage, explosion, fire or death.

Sequence of Operation

Starting Circuit: Upon a call for heat, voltage is applied to L1 and Neutral. After a pre-purge, the spark electrode is energized and the gas valve opens. The trial for ignition is 15 seconds. If flame is not sensed, the heater will attempt two more times to reignite.

Running Circuit: After ignition, the sensing electrode monitors the burner flame. If sense of flame is lost, the control immediately acts to reignite the gas-air mixture. If flame sense is not established within 15 seconds, the heater will attempt two additional ignition sequences before proceeding to hard lockout. The control can be reset by briefly interrupting the power source.

Dayton® High Intensity Heaters

4.0 Maintenance

It is recommended that the following become a standard yearly procedure to obtain maximum operating efficiency and trouble free operation.

During long periods of non-usage, remove or cover heater with a polyethylene bag and shut off gas supply. If further service to the heater is desired, contact your representative or the factory.

Main Burner

1. Gently use an air hose to blow any accumulated dust and/or dirt off the heater. Air hose pressure must not exceed 30 psig.
2. Gently pass the air hose over the area of the ceramic. A distance of 2 ft. to 4 ft. from the unit is recommended. **NOTE:** Blowing out the gasket material will permanently damage the rayhead.
3. Gently place the air hose outlet into each venturi tube and allow the air to flow for approximately one minute.
4. See troubleshooting chart (page 21) if there are any signs of burner malfunction. Replace if necessary.

Gas Supply

1. Periodically inspect the gas supply for signs of corrosion or failure. Replace if necessary.

⚠ WARNING



Use protective glasses when cleaning the heater.



Disconnect power to heater before servicing.



Do not operate unit if repairs are necessary. Do not operate unit showing any signs of burner malfunction. Call a professional for assistance.

CAUTION



Avoid Equipment Failure.

Do not blow out heating elements with high pressure air.

Models 3E132E thru 3E134E, 3E460C thru 3E462C, 5VD57 thru 5VD66, 3VH34 thru 3VH37

Chart 4.1 Troubleshooting Guide

Symptom	Possible Cause	Corrective Action
Burning of gas-air mixture inside plenum (flashback).	<ul style="list-style-type: none"> • Heater mounted at incorrect angle. • Excessive drafts. • Gas leaking or blocked orifice/venturi. • Separation of ceramic grids. • Ceramic grids cracked. 	<ul style="list-style-type: none"> • Mounting angle 20°-35° from horizontal. • Relocate or shield from draft. • Do not operate unit. Check with leak detector solution. • Do not operate unit. Replace rayhead. • Do not operate unit. Replace rayhead.
Delayed ignition.	<ul style="list-style-type: none"> • Electrode out of specification. • Low gas pressure. • Partially blocked orifice. • Improper orifice size. • Incorrect gas. 	<ul style="list-style-type: none"> • See figure 4.2. • See Gas Supply section. • Clean or replace. • Consult dealer. • Do not operate unit. See unit nameplate. Correct immediately.
Low ceramic surface temperature, excessive rollout or soot on rods.	<ul style="list-style-type: none"> • Dirty or plugged rayhead ceramics. • Partially blocked orifice. • Low inlet gas pressure. • Low manifold gas pressure. • High manifold pressure. • Foreign matter in venturi tube. • Gas supply piping too small . • Incorrect gas. 	<ul style="list-style-type: none"> • See maintenance instructions. • Remove and clean. • See Gas Supply section. • Adjust main valve regulator for 6 Inches W.C. natural gas, 10 Inches W.C. propane. • Adjust main valve regulator for 6 Inches W.C. natural gas, 10 Inches W.C. propane. • See periodic maintenance instructions. • Increase inlet pressure or replace. • Do not operate unit. See unit nameplate. Correct immediately.
Control system overheating.	<ul style="list-style-type: none"> • Heater not mounted correctly. • Heater mounted too close to ceiling. 	<ul style="list-style-type: none"> • Mounting angle 20°-35° from horizontal. • Observe clearance to combustibles safety chart located on heater reflector. Do not operate unit.
Gas odor.	<ul style="list-style-type: none"> • Loose pipe connection. 	<ul style="list-style-type: none"> • Check all connections with leak-detector solution, tighten as necessary.
Heater cycles repeatedly.	<ul style="list-style-type: none"> • Heater located in drafty area. • Low gas pressure. • Thermostat located in drafty area. • Weak pilot flame. 	<ul style="list-style-type: none"> • Relocate or shield from draft. • See Gas Supply section for propane. • Replace thermostat. • Clean or adjust pilot.
No spark; no ignition.	<ul style="list-style-type: none"> • Lack of 120 or 24VAC incoming voltage. • Open high voltage wire. • Improper electrode gap. • Loose or open wire connection. • Poor or no equipment ground. • Unit in "safety lockout" mode. • Defective "gas lighter" control. 	<ul style="list-style-type: none"> • Proper voltage needed or repair wire. • Isolate and measure for resistance, replace if "0". • See figure 4.2. • Check all wires, tighten or replace. • Trace ground wire for complete circuit back to equipment ground from control. • Interrupt power source, repeat trial for ignition. • Verify proper voltage. Replace.
Heater lights, and "locks out" after approximately 10 seconds.	<ul style="list-style-type: none"> • Poor or no equipment ground. • Polarity is reversed. • Low gas pressure. • Electrode not sensing. • Heater mounted at incorrect angle. 	<ul style="list-style-type: none"> • Check all connections, provide positive earth ground. • 120VAC to black, neutral to white. • See Gas Supply section. • Relocate or replace if defective. • Mounting angle 20°-35° from horizontal.
Spark is present. No main gas operation. Unit "locks out".	<ul style="list-style-type: none"> • Gas valve in "Off" position. • Defective main valve solenoid. • Defective "Gas lighter" control. 	<ul style="list-style-type: none"> • Turn to "On" position. • Isolate and check for resistance. Replace if "0". • Verify proper voltage. Replace.
Heater will not shut off.	<ul style="list-style-type: none"> • Defective thermostat or wiring. • Gas valve stuck open. • High gas pressure. 	<ul style="list-style-type: none"> • Replace or repair. • Replace. • See Gas Supply section.

E
N
G
L
I
S
H

Dayton® High Intensity Heaters

Heater Assembly Components

NOTE: Replacement burners are called "rayheads" with rod inserts (part no. DR-RH and DR-ROD).

Ceramic grids are not sold separately, order full assembly (part no. DR-RH).

Figure 4.1 - Heater Assembly Components (side view)

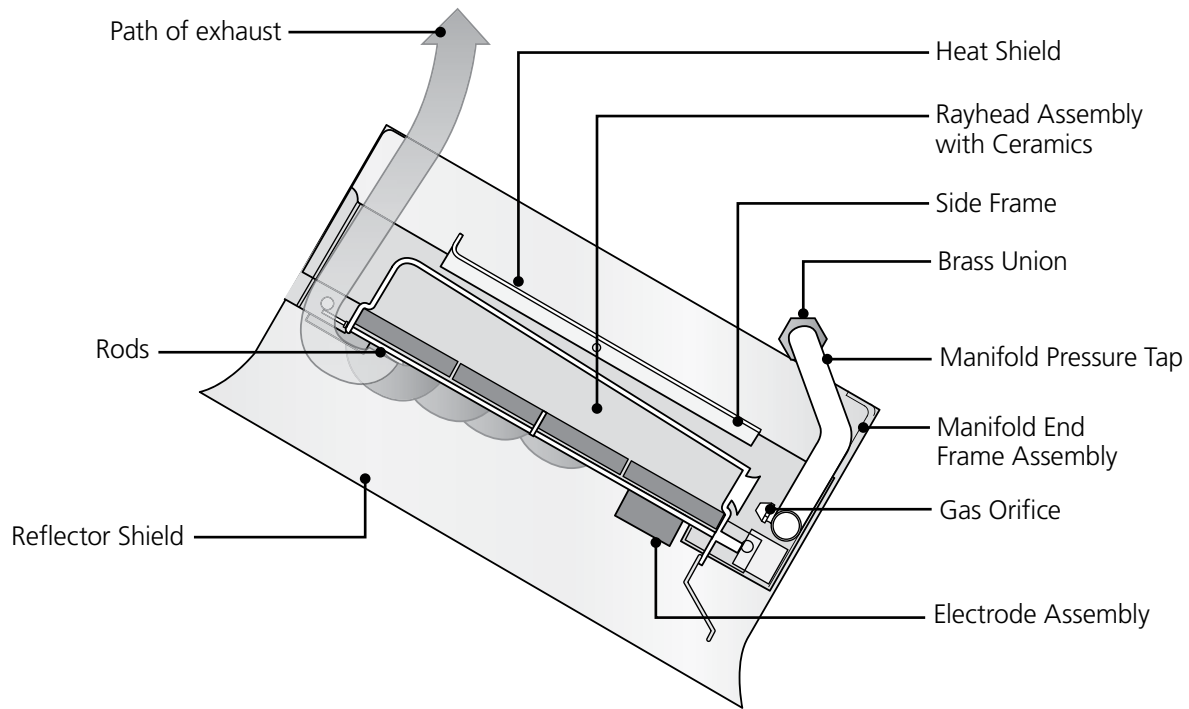

Figure 4.2 - Spark Electrode Side View

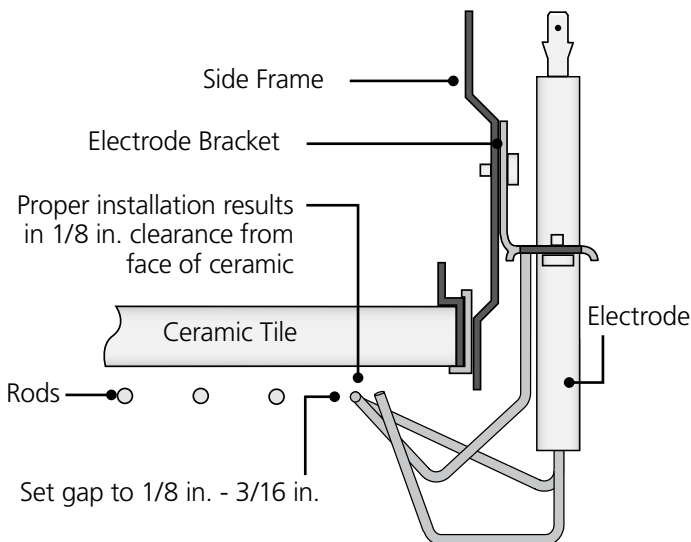
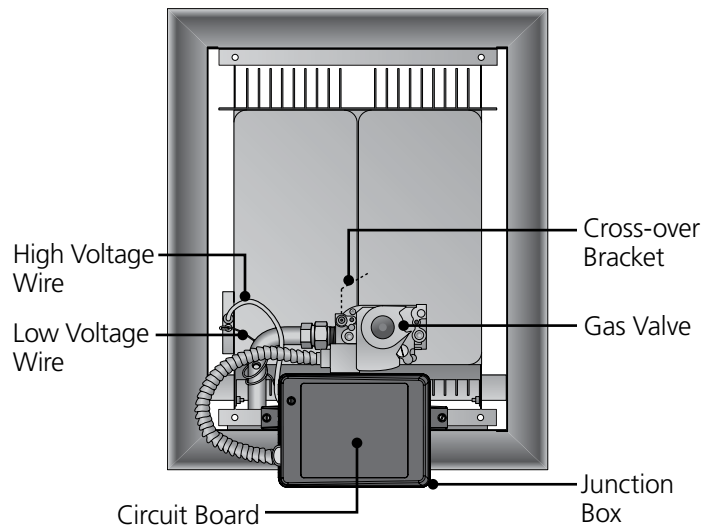

Figure 4.3 - Heater Components (rear view)



E
N
G
L
I
S
H

Models 3E132E thru 3E134E, 3E460C thru 3E462C, 5VD57 thru 5VD66, 3VH34 thru 3VH37

Parts Listing

Chart 4.2 - Direct Spark Control Components

Part No.	Description	Voltage
VR8205A-2123	Combination gas valve, natural gas	25VAC
VR4205M-1308	Combination gas valve, natural gas	120VAC
DR-V24LP	Combination gas valve, propane gas	25VAC
VR4205M-1357	Combination gas valve, propane gas	120VAC
32-508	Main burner electrode	25VAC, 120VAC
Mark-10DX-24	25VAC circuit board	25VAC
DRWH-24	Wiring harness for Mark-10DX-24 circuit board	25VAC
Mark-10DX-117	120VAC circuit board	120VAC
DRWH-120	Wiring harness for Mark-10DX-117 circuit board	120VAC
HVW-18	High voltage ignition wire	25VAC, 120VAC
LVW-18	Low voltage ignition wire	25VAC, 120VAC

Chart 4.3 - Miscellaneous Core Components

Part No.	Description	Part No.	Description
DR-MAN#	Manifold (specify 1, 2 or 3)	DR-SROD	Short rayhead rod
DR-UF#	Upper frame	DR-MU	3-piece brass union
DR-HS#	Heat shield (specify 1, 2 or 3)	ORF-#	Brass gas orifice (specify model number)
DR-FLSH#	Flash shield (specify 1, 2 or 3)	DR-FC	3/8 in. flex conduit
DR-RFE#	Reflector End (specify 1, 2 or 3)	DR-FL31	3/8 in. conduit attachment fitting
DR-#REF	Full Reflector Assembly (specify 1, 2 or 3)	DR-EMB	Electrode mounting bracket
DR-SF	Side frame	DR-RSB	Red Rubber Spark Boot
DR-SFI	Side frame insert	DR-LVG	Low volt black wire grommet
DR-ERS	Embossed reflector sides	DR-HVG	High volt black wire heyco grommet
DR-RH	Rayhead with center support	DR-PJBT	Plastic junction box (Top)
DR-RHP	Rayhead no center support (3E460 and 5VD62 only)	DR-PJBB	Plastic Junction Box (Bottom)
		DR-20MB	#20tpi 1/4 in. x 1/2 in. Machine Screw
DR-CO	Cross-over bracket	DR-20HN	#20tpi 1/4 in. x 1/2 in. - Hex Nut (mates to DR-20MB)
DR-LROD	Long rayhead rod	DR-20STB	1/4 - 20 x 1/2 in. self-tap DR bolt

Reference proper part number when ordering these parts:

- 1 = 3E132, 3E460, 5VD61, 5VD62
- 2 = 3E133, 3E461, 5VD63, 5VD64
- 3 = 3E134, 3E462, 5VD65, 5VD66

IMPORTANT: Contact factory for conversion assistance. Gas type conversions require gas valve, gas orifice among other changes. Conversion may also require burner and crossover changes.

Dayton® High Intensity Heaters

5.0 Limited Warranty

Dayton One-Year Limited Warranty. Dayton Radiant High Intensity Heaters, Models 3E132, 3E460, 5VD61, 5VD62, 3E133, 3E461, 5VD63, 5VD64, 3E134, 3E462, 5VD65, 5VD66 covered in this manual, are warranted by Dayton Electric Mfg. Co. (Dayton) to the original user against defects in workmanship or materials under normal use for one year after date of purchase. Any part which is determined to be defective in material or workmanship and returned to an authorized service location, as Dayton designates, shipping costs prepaid, will be, as the exclusive remedy, repaired or replaced at Dayton's option. For limited warranty claim procedures, see PROMPT DISPOSITION below. This limited warranty gives purchasers specific legal rights which vary from jurisdiction to jurisdiction.

Additional Limited Warranty. In addition to the above mentioned one-year warranty, Dayton warrants the original purchaser an additional 4-year extension on the ceramic burner (DR-RH Rayhead Assembly). This extension excludes electrical/purchased components.

Limitation of Liability. To the extent allowable under applicable law, Dayton's liability for consequential and incidental damages is expressly disclaimed. Dayton's liability in all events is limited to and shall not exceed the purchase price paid.

Warranty Disclaimer. Dayton has made a diligent effort to provide product information and illustrate the products in this literature accurately; however, such information and illustrations are for the sole purpose of identification, and do not express or imply a warranty that the products are merchantable, or fit for a particular purpose, or that the products will necessarily conform to the illustrations or descriptions. Except as provided below, no warranty or affirmation of fact, expressed or implied, other than as stated in the "LIMITED WARRANTY" above is made or authorized by Dayton.

Product Suitability. Many jurisdictions have codes and regulations governing sales, construction, installation, and/or use of products for certain purposes, which may vary from those in neighboring areas. While Dayton attempts to assure that its products comply with all codes, it cannot guarantee compliance, and cannot be responsible for how the product is installed or used. Before purchase and use of a product, review the product applications, and all applicable national and local codes and regulations, and be sure that the product, installation, and use will comply with them.

Certain aspects of disclaimers are not applicable to consumer products: e.g., (a) some jurisdictions do not allow the exclusion or limitation of incidental or consequential damages, so the above limitation or exclusion may not apply to you: (b) also, some jurisdictions do not allow a limitation on how long an implied warranty lasts, consequently the above limitation may not apply to you: and (c) by law, during the period of this limited warranty, any implied warranties of implied merchantability or fitness for a particular purpose applicable to consumer products purchased by consumers, may not be excluded or otherwise disclaimed.

Prompt Disposition. Dayton will make a good faith effort for prompt correction or other adjustment with respect to any product which proves to be defective within limited warranty. For any product believed to be defective within limited warranty, first write or call dealer from whom the product was purchased. Dealer will give additional directions. If unable to resolve satisfactorily, write to Dayton at address below, giving dealer's name, address, date and number of dealer's invoice, and describe the nature of the defect. Title and risk of loss pass to buyer on delivery to common carrier. If product was damaged in transit to you file claim with carrier.