

Twist-Lock® Devices
 15A, 125V, 2 Pole, 3 Wire Grounding
 Elastogrip® Connector

HUBBELL

Features

- Integral weatherproofing shroud seals connection between plug and connector
- Nylon compression nut keeps water and dust from getting into the body around the cord



Ordering Information

Description	Cord Diameter	UPC	Catalog Number
Elastogrip® Connector, yellow elastomer, water/dust tight	.300"-.655" (7.6-16.6)	783585235912	HBL25W47

Listings

Listed to UL 498
 Fed.Spec. W-C-596
 Certified to CSA C22.2 No.42

Specifications

Terminal Retainer	Clear polycarbonate
Strain Relief Nut	Nylon
Contacts	Brass
Terminal Screws	Brass
Assembly Screws	Steel, zinc plated

Performance

Electrical

Current Interrupting	Certified for current interrupting at full rated current
Dielectric Voltage	Withstand 2,000V minimum

Mechanical

Terminal Accommodation	#18 AWG- #10 AWG stranded copper wire only.
------------------------	---

Terminal Identification	Terminals identified in accordance with UL 498
-------------------------	--

Environmental

Flammability	HB or better per UL94/CSA 22.2 No.0.17
Moisture Resistance	IP20 Suitability
Operating Temperatures	Maximum Continuous 75°C; Minimum -40°C (w/o impact)

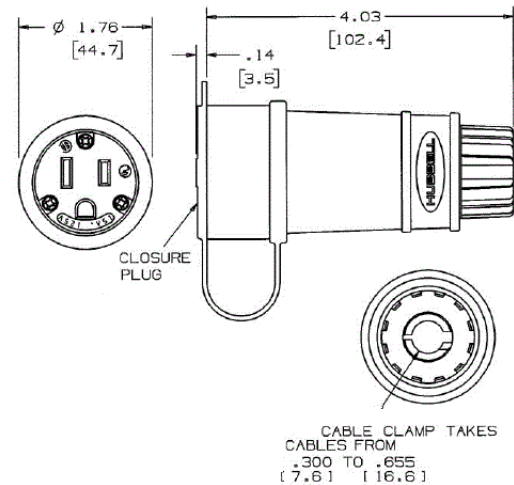

Accessories

Plug	HBL24W47
------	----------

Resources

Customer Use Drawing
 eCatalog

Dimensions in Inches (mm)

Hubbell Wiring Device-Kellems • Hubbell Incorporated (Delaware) • 40 Waterview Drive • Shelton, CT 06484

Phone (800) 288-6000 • Fax (800) 255-1031 • Specifications subject to change without notice.

