

M-13315

2

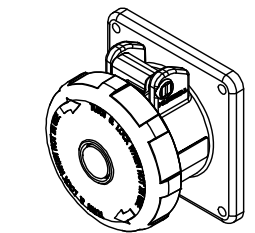
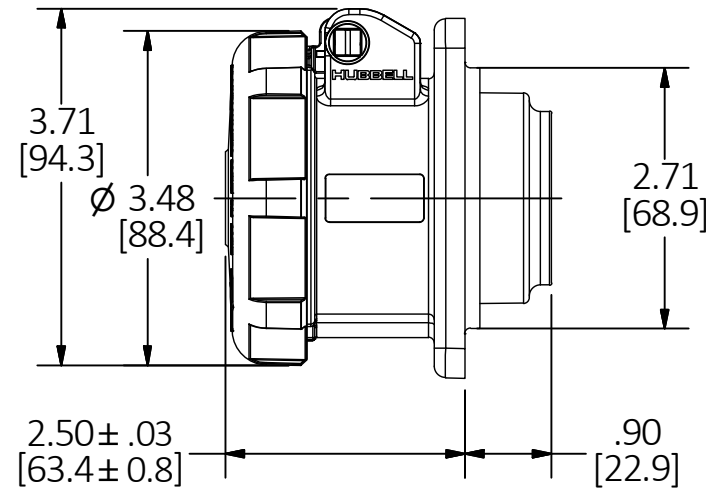
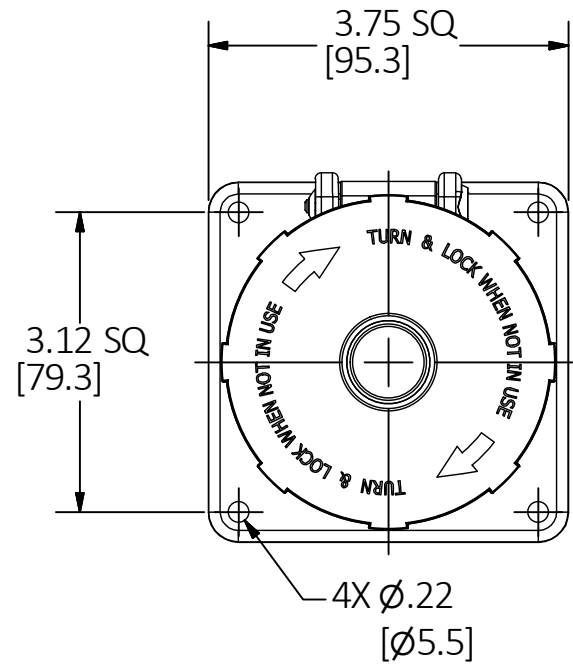

LIST OF PARTS		
DESCRIPTION	MATERIAL	FINISH
HOUSING	PBT	
INTERIOR	THERMOSET	
SLEEVES	BRASS	
SLEEVE SPRINGS	ST. STEEL	
TERMINAL SCR.	ST. STEEL	
COVER	PBT	
GASKET	CLOSED CELL FOAM	
HINGE ARM	PBT	
HINGE PIN	BRASS	NICKEL
HINGE SPRING	ST. STEEL	
GLAND CAP	PBT	
GLANDS	NEOPRENE	
CLAMPS	PBT	
CLAMP NUTS	BRASS	NICKEL
ASSY. SCREWS	ST. STEEL	

CAT. NO.	CONFIG.	RATING	HOUSING COLOR
HBL516R1W		BARGE OVERFILL CONTROL	BLUE
HBL520R5W		20A 347/600VAC 3Ø	BLACK
HBL520R6W		20A 200/346-240/415VAC 3Ø 16A - 6h/200/346-240/415~	RED
HBL520R7W		20A 277/480VAC 3Ø	RED
HBL520R9W		20A 120/208VAC 3Ø 16A - 9h/120/208-144/250V~	BLUE

REV	DESCRIPTION	APP	DATE
2	REVISED HBL520R6W RATING INFO PER DCN 22751 Mr.B	TLS	11/15/16
1	INITIAL RELEASE PER DCN 21982 Mr.B	TLS	3/10/16

THE DESIGN AND DIMENSIONS OF THE PRODUCT SHOWN ON THIS DRAWING ARE SUBJECT TO CHANGE WITHOUT NOTICE. DIMENSIONS ARE IN INCHES [mm].

TITLE  
20A & 16A 4 POLE 5 WIRE PIN AND SLEEVE RECEPTACLE



WIRING DEVICE-KELLEMS  
HUBBELL INCORPORATED  
SHELTON, CT

TOLERANCES UNLESS OTHERWISE SPECIFIED  
.XX = ± .01  
.XXX = ± .005  
ANGLE TOL. ±2'

DR. BY	Mr.B	SCALE	1 : 2
CHK. BY	TLS	DATE	3/2/16

DIMENSION SHEET FOR CAT. NO. SEE TABLE

B

M-13315

2