

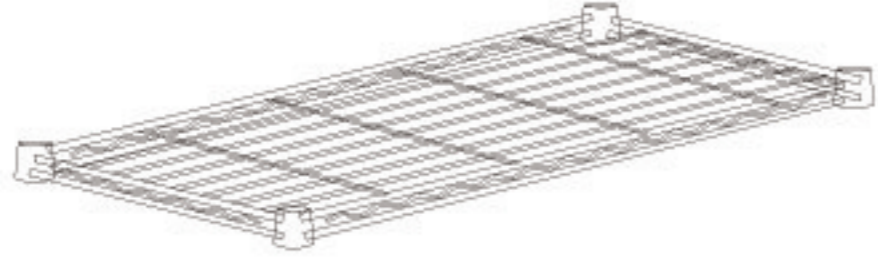



2-TIER HEAVY DUTY WIRE CART ASSEMBLY INSTRUCTION

NO	A	B	C	D	E
Parts	Side Post 	Shelf 	Plastic Split Sleeve 	Plastic Bumper 	Caster 
	Qty. 2PCS	2PCS	10 Pairs(2 pairs spare parts)	4PCS	4PCS

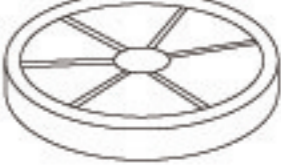

1. Slide Shelf (B) to top of Side Posts (A). Locate the ridges of the Plastic Split Sleeves (C) into Side Posts (A) at desired height. Guide down to tapered Plastic Split Sleeves (C).

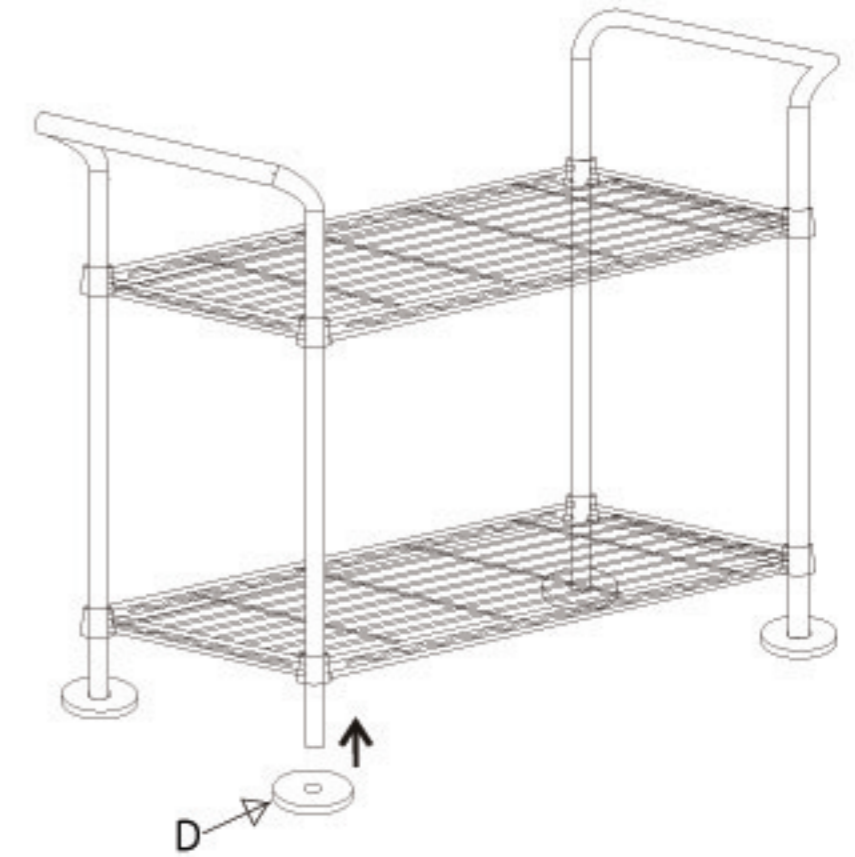
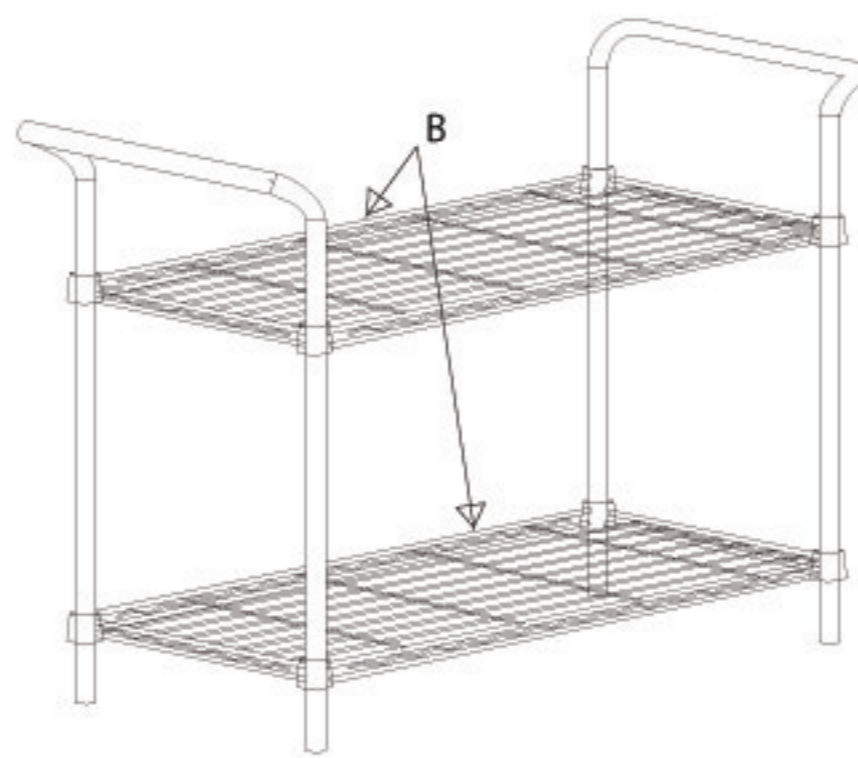
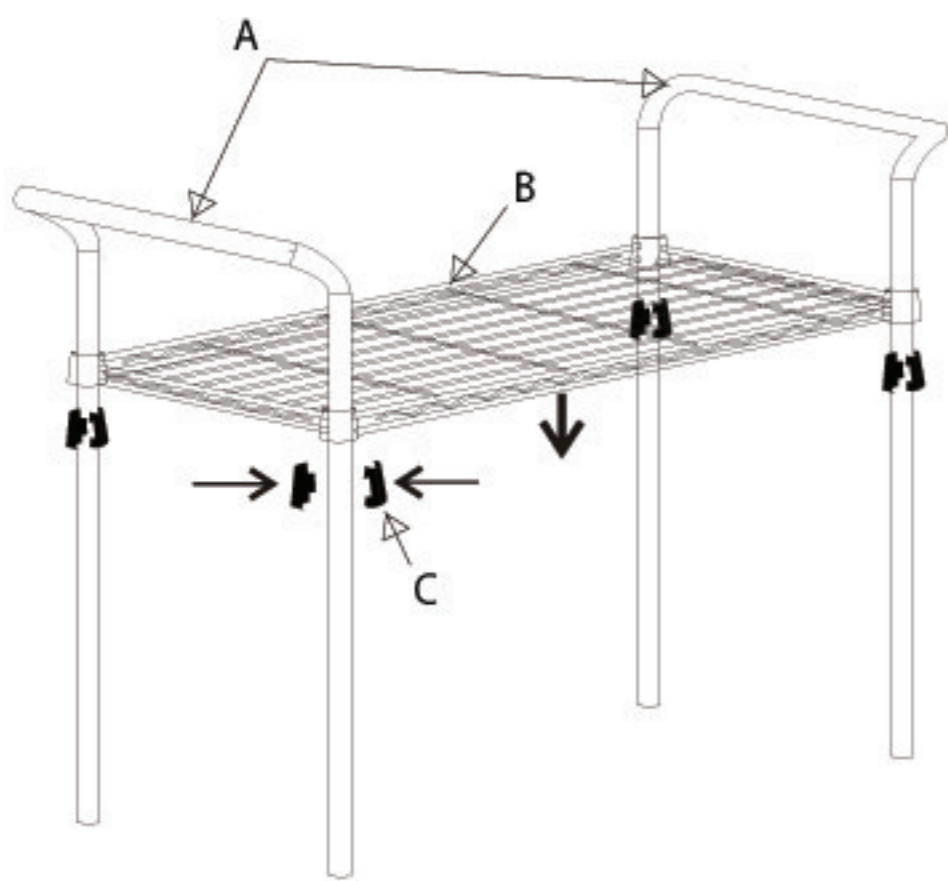
2. Repeat step 1 for the remaining shelf.

3. Fix the Plastic Bumpers (D) onto the bottom of each post.



4. Insert the Casters (E) in to the bottom of each post.



5. It is now ready for use.

Specification List

SKU#	Product Dimension (INCH)	Maximum Load Capacity (LBS)	Part Numbers				
			A	B	C	D	E
1ECJ2	18 (D) x 36 (W) x 39(H)	600	1G0210566	MH1836CG	MHSLEEVEG	1G0210565	1ZTJ1
1ECJ3	18 (D) x 48 (W) x 39 (H)	600	1G0210566	MH1848CG	MHSLEEVEG	1G0210565	1ZTJ1
1ECJ4	24 (D) x 36 (W) x 39(H)	600	1G0210685	MH2436CG	MHSLEEVEG	1G0210565	1ZTJ1
1ECJ5	24 (D) x 48 (W) x 39 (H)	600	1G0210685	MH2448CG	MHSLEEVEG	1G0210565	1ZTJ1

WARNING: Maximum load capacity as shown above is equally distributed.



Manufactured For Grainger International
Lake Forest, IL 60045
Made in China